



Digital 280-1 digital indicator



BluePort® Front interface and BlueControl Software

Maintenance manager and error list

Large 5-digit display

Limit values with hysteresis, time gate and gradient

ON/OFF and 2-point controller

O₂ measurement with high-impedance input

Functions-key

universal line

- ⊕ Customer-specific linearization for all sensors
- ⊕ Galvanically isolated output
- ⊕ Permanent min. and max. value storage (slave pointer)
- ⊕ Tare function
- ⊕ Sample & hold amplifier
- ⊕ Filter with suppression bandwidth (adjustable)
- ⊕ Einstellbare Auflösung der Anzeige
- ⊕ Settings can be blocked via password and internal switch for high security
- ⊕ Extended temperature range up to 60 °C allows mounting close to the process
- ⊕ Easy 2-point or offset measurement correction
- ⊕ Logical combination of digital outputs, e.g. for general alarm
- ⊕ RS 422/485 Modbus RTU interface
- ⊕ Built-in transmitter power supply
- ⊕ Splash-water proof front (IP 65)

APPLICATIONS

- Furnaces and ovens
- Burners and boilers
- Weighing and batching
- Process control
- Plastics processing
- ...

DESCRIPTION

Front interface and Engineering Tools

Control parameter adjustment in seconds has now also been implemented in the KS 40 class of instruments. Via the BlueControl software incl. its simulation functions, and especially the convenient BluePort® front panel interface, the required set-up for a specific control task can be determined without a detailed study of the operating instructions. Off cause almost all adjustments can be done comfortably over the instrument front. (see page 5, BlueControl)

Limit values

The measured signal can be scaled freely and monitored for limit values and sensor break. Process status signalling is possible by two relays and six LEDs in total. Moreover, an alarm or the displayed value can be output as a 0/4...20 mA or 0/2...10 V signal via an analog output.

Alarm hold function

Alarm statuses can be configured so that they remain unchanged until acknowledgement.

Controller

Apart from application as an indicator, Digital 280-1 can be used as a signaller or on/off controller, as a two-point or a continuous controller.

Oxygen measurement:

When using a heated lambda probe, the oxygen concentration can be displayed, controlled and output directly as a standard signal.

Range with O₂ measurement: 0,0001% (1ppm) to 100.00% Indication of values below 1 ppm is possible via the voltage value display.

Linearization with 15 segments

Non-linear signals, e.g. filling quantities, flows, etc. can be adapted by means of user-specific linearization.

Plug-in module

As a plug-in module, Digital 280-1 can be replaced very quickly without tools and without impairing the wiring.

Password protection

If required, access to the various operating levels can be protected with a password.

TECHNICAL DATA

INPUTS

PROCESS VALUE INPUT INP1

Resolution:	> 15 Bit
Decimal point:	0 bis 4 Nachkommastellen
Limiting frequency:	2 Hz (analog)
Digital input filter:	adjustable 0,1...100 s
Scanning cycle:	100 ms
Measured value correction:	2-point or offset correction

Thermocouples (Table 1)

Input impedance:	≥ 1 MΩ
Effect of source resistance:	1 μV/Ω

Cold junction compensation

Internal temperature compensation	
Max. additional error	± 0,5 K

External temperature compensation adjustable within 0 and 100 °C or 32 and 212 °F

Sensor break monitoring

Sensor current:	≤ 1 μA
-----------------	--------

Resistance thermometer (Table 2)

Connection:	3-wire
Lead resistance:	max. 30 Ω
Input circuit monitor:	Break and short circuit

Resistance measuring range

The BlueControl software can be used to match the input to the sensor KTY 11-6 (characteristic is stored in the controller).

Physical measuring range:	0...450 Ohm
	0...4500 Ohm
Linearization segments	15

Current and voltage signals (Table 2)

Span start, end of span:	anywhere within measuring range
Scaling:	selectable -19999...99999
Linearization:	15 segments, adaptable with BlueControl
Decimal point:	adjustable
Input circuit monitor:	with 4...20mA and 2...10V 12,5% below span start (2mA, 1V)

CONTROL INPUT DI1

Configurable as direct or invers switch or push-button !
Connection of a potential-free contact suitable for switching „dry“ circuits.

Switched voltage:	2,5 V
Switched current:	50 μA

Table 1 Thermocouple ranges

Thermocouple		Range		Accuracy	Resolution (∅)
L	Fe-CuNi (DIN)	-100...900°C	-148...1652°F	≤ 2 K	0,05 K
J	Fe-CuNi	-100...1200°C	-148...2192°F	≤ 2 K	0,05 K
K	NiCr-Ni	-100...1350°C	-148...2462°F	≤ 2 K	0,1 K
N	Nicrosil/Nisil	-100...1300°C	-148...2372°F	≤ 2 K	0,1 K
S	PtRh-Pt 10%	0...1760°C	32...3200°F	≤ 2 K	0,1 K
R	PtRh-Pt 13%	0...1760°C	32...3200°F	≤ 2 K	0,1 K
T	Cu-CuNi	-200...400°C	-328...752°F	≤ 2 K	0,025 K
C	W5%Re-W26%Re	0...2315°C	32...4199°F	≤ 2 K	0,2 K
D	W3%Re-W25%Re	0...2315°C	32...4199°F	≤ 2 K	0,2 K
E	NiCr-CuNi	-100...1000°C	-148...1832°F	≤ 2 K	0,05 K
B ⁽¹⁾	PtRh-Pt6%	0(100)...1820°C	32(212)...3308°F	≤ 3 K	0,15 K
special		-25...75 mV		≤ 0,1 %	0,005 %

⁽¹⁾ Specifications for type B are valid from 100°C.

Table 2 Resistance transducers

Type	Sensor current	Range		Accuracy	Resolution (∅)
Pt100	0,2 mA	-200...850°C	-328...1562°F	≤ 1 K	0,05 K
Pt1000		-200...200°C	-328...392°F	≤ 2 K	
Spezial*		0...4500 Ω**		≤ 0,1 %	0,005 %
Spezial		0...450 Ω**			
Poti		0...160 Ω**			
Poti	0...450 Ω**				
Poti	0...1600 Ω**				

* Characteristic KTY 11-6 (-50...150°C) is factory-set.

** inclusive of lead resistance

Table 3 Current and voltage

Range	Input resistance	Accuracy	Resolution (∅)
0...20 mA	49 Ω (voltage requirement ≤ 2,5 V)	≤ 0,1 %	0,75 μA
0...10 Volt	≈ 110 kΩ	≤ 0,1 %	0,4 mV
-2,5...115 mV*	≥ 1MΩ	≤ 0,1 %	4 μV
-25...1150 mV*	≥ 1MΩ	≤ 0,1 %	40 μV
-50...50 mV*	≥ 1MΩ	≤ 0,1 %	4μV
-500...500 mV*	≥ 1MΩ	≤ 0,1 %	40 μV
-5...5Volt	≈ 110 kΩ	≤ 0,1 %	0,4 mV

* high-impedance voltage ranges without break monitoring

CONTROL INPUTS DI2, DI3 (OPTION) FILTER

In common with DI1 configurable as switch or push-button !
Optocoupler input for active triggering

Nominal voltage:	24 V DC, external
Current sink (IEC 1131 Type 1)	
Logic „0“:	-3...5 V
Logic „1“:	15...30 V
Current requirement:	approx. 5 mA

TRANSMITTER SUPPLY U_T (OPTION)

Output:	22 mA / ≥ 18 V
---------	----------------

If the universal output OUT3 is used there may be no external galvanic connection between measuring and output circuits!

A 1st order mathematic filter adjustable for time constant and bandwidth is built in.

Filterfunktion

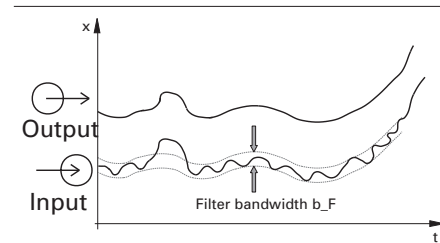

The bandwidth is the adjustable tolerance around the process value in which the filter is active. Measured value changes exceeding the adjusted bandwidth are passed through directly.

OUTPUTS

Survey of the outputs

Output	Used for:
OUT1 (relay) OUT2 (relay) OUT3 (logic)	Limit contacts, alarms Control output
OUT3 (continuous)	Control output, process value, set-point, control deviation, transmitter supply 13 V / 22 mA

* All logic signals can be OR-linked !

RELAY OUTPUTS OUT1, OUT2

Contacts: 2 NO contacts with common connection
 Max. contact rating: 500 VA, 250 VAC, 2A at 48...62 Hz, resistive load
 Min. contact rating: 6 V, 1 mA DC
 Operating life (electric): 800.000 duty cycles with max. rating

Note:
 If the relays OUT1...OUT3 operate external contactors, these must be fitted with RC snubber circuits to manufacturer specifications to prevent excessive switch-off voltage peaks.

OUT3 AS UNIVERSAL OUTPUT

Galvanically isolated from the inputs.

Freely scalable
 DA-converter limiting frequency T_{90} : 50 ms
 Limiting frequency of the complete continuous controller: > 2 Hz
 Resolution: 11 bits

Current output

0/4...20 mA, configurable.
 Signal range: 0...approx. 21,5 mA
 Load: $\leq 500 \Omega$
 Load effect: 0,02 % / 100 Ω
 Resolution: $\leq 22 \mu A$ (0,1%)
 Error: $\leq 40 \mu A$ (0,2%)

Voltage output

0/2...10V, configurable
 Signal range: 0...11 V
 Load: $\geq 2 k\Omega$
 Load effect: no Effect
 Resolution: $\leq 11 mV$ (0,1%)
 Error: $\leq 20 mV$ (0,2%)

OUT3 used as transmitter supply

Output: 22 mA / $\geq 13 V$

OUT3 used as logic output

Load $\leq 500 \Omega$ 0/ $\leq 20 mA$
 Load > 500 Ω 0/> 13 V

Electrical connections:

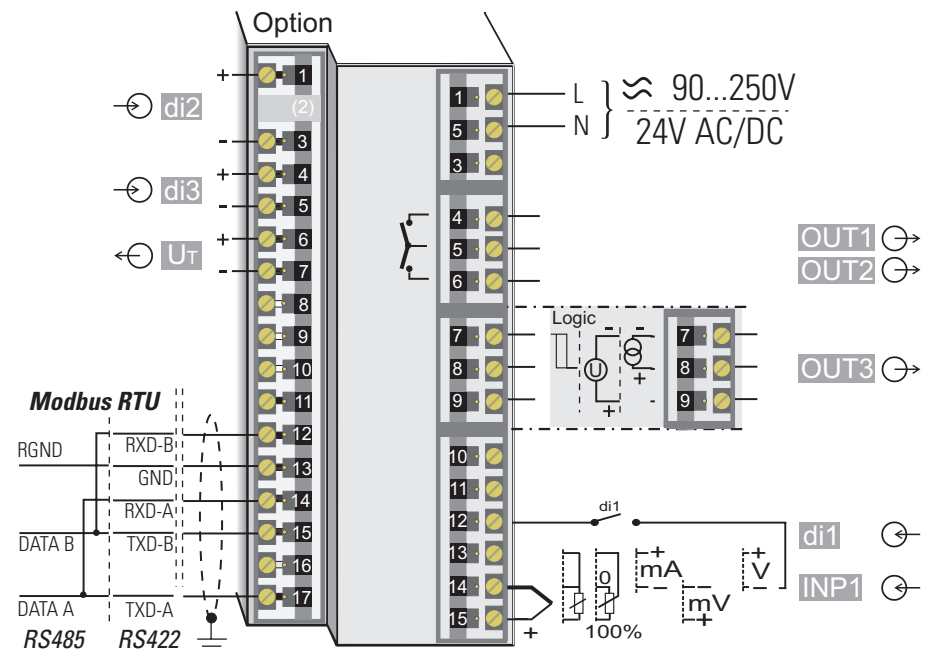

* Pay attention to the internal switch!

FUNCTIONS

Control behaviour

- Signaler with adjustable switching differential (ON/OFF controller)
 - PID controller (2-point and continuous)
- Self-tuning control parameters or adjustable manually via front keys or BlueControl software.

Limit signalling functions

Monitoring for: exceeded max., min. or max. and min. limit value is provided.

Signals which can be monitored:

- Input signal
- Process value
- Control deviation
- Control deviation with suppression during start-up or set-point changes
- set-point
- Output signal Y

Functions

- Input signal monitoring
- Input signal monitoring with latch (reset via front key or digital input)
- Measured value change
- Measured value change and storage

Several limit signals or alarms can be OR-linked before being output. General alarms, etc.

ALARM + MAINTENANCE MANAGER

Display of error signals, warnings, and latched limit messages in the error list. Signals are latched, and can be reset manually.

Possible signals in the error list:

- Sensor break, short circuit, reversed polarity
- Fault during self-tuning
- latched limit messages e.g. re-calibration warning
- (If the adjusted operating hours are exceeded a message is displayed) e.g. maintenance interval of actuator
- (If the adjusted switching cycles are exceeded a message is displayed)
- Internal fault (RAM, EEPROM, ...)

Flashing Error LED indicates active alarm in the error list:



DISPLAY

Display

5-digit, 19mm LED

POWER SUPPLY

Depending on version:

AC SUPPLY

Voltage:	90...260 VAC
Frequency:	48...62 Hz
Power consumption	approx. 7 VA

UNIVERSAL SUPPLY 24 V UC

AC voltage:	20,4...26,4 VAC
Frequency:	48...62 Hz
DC voltage:	18...31 V DC
Power consumption:	approx: 7 VA (W)

BEHAVIOUR WITH POWER FAILURE

Configuration, parameters, and adjusted set-points and the operating statuses are stored in non-volatile EEPROM.

BluePort FRONT INTERFACE

Connection of PC via PC adapter (see „Accessories“). The BlueControl software is used to configure, set parameters, and operate the Digital 280-1.

BUS INTERFACE (OPTION)

Galvanically isolated

Physical:	RS 422/485
Protocol:	Modbus RTU
Transmission speed:	2400, 4800, 9600, 19.200 bits/s
Address range::	1...247
Number of controllers per bus:	32
Repeaters must be used to connect more controllers.	

Overall dimensions::

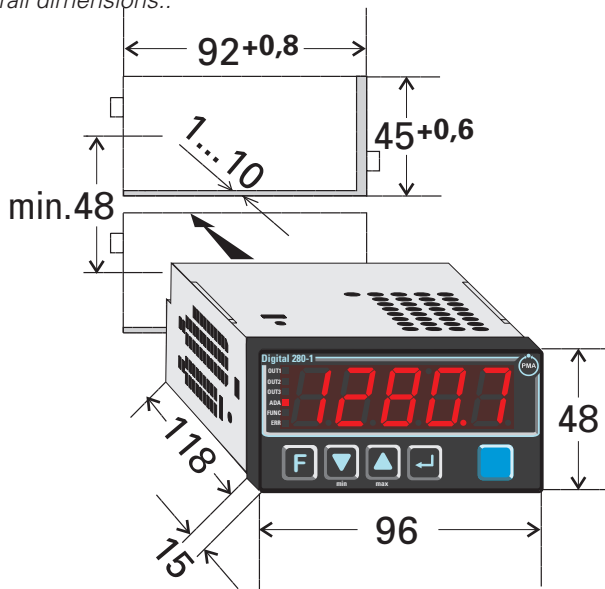

ENVIRONMENTAL CONDITIONS

Protection modes

Front panel:	IP 65
Housing:	IP 20
Terminals:	IP 00

Permissible temperatures

For specified accuracy:	0...60°C
Warm-up time:	< 15 minutes
Temperature effect:	< 100ppm/K
For operation:	-20...65°C
For storage:	-40...70°C

Humidity

75% yearly average, no condensation

Shock and vibration

Vibration test Fc (DIN 68-2-6)

Frequency:	10...150 Hz
Unit in operation:	1g or 0,075 mm
Unit not in operation:	2g or 0,15 mm

Shock test Ea (DIN IEC 68-2-27)

Shock:	15g
Duration:	11ms

Electromagnetic compatibility

Complies with EN 61 326-1

- Complies with the immunity requirements for continuous, unattended operation
 - Complies with the emission requirements class B for rural areas
- Surge disturbances may increase the measurement error

GENERAL

Housing

Material:	Makrolon 9415, flame-retardant
Flammability class:	UL 94 V0, self-extinguishing
Plug-in module, inserted from the front	

Safety tests

Complies with EN 61010-1 (VDE 0411-1):
Over voltage category II
Contamination class 2
Working voltage range 300 VAC
Protection class II

Certifications

Type test to DIN 3440

With certified sensors it can be used in:

- Heat generating plants with outflow temperatures up to 120°C to DIN 4751
- Hot-water plants with outflow temperatures above 110°C to DIN 4752
- Thermal transfer plants with organic transfer media to DIN 4754

Oil-heated plants to DIN 475

UL certification (applied for)

Electrical connections

- Screw terminals for conductor cross-section from 0,5 to 2,5 mm²

Mounting

Panel mounting with two fixing clamps at top/bottom or left/right
Close mounting possible

Mounting position:	not critical
Weight:	0,27 kg (9.52 oz)

Accessories supplied with unit

Operating instructions
2 fixing clamps

ACCESSORY EQUIPMENT

BlueControl (Engineering Tool)

PC-based program for configuring, setting parameters, and operating (commissioning) Digital indicator, controller and temperature limiter of the BluePort® series.

Software requirements:
Windows 95/98/NT/2000.

The built-in simulation serves to test the controller settings, but can also be used for general training and observing the interaction between controller and control loop.

Display of two parameters was suppressed:

Name	Description	Visible
Lim	Limit	<input checked="" type="checkbox"/>
L.1	lower limit 1	<input type="checkbox"/>
H.1	upper limit 1	<input type="checkbox"/>
HYS.1	hysteresis 1	<input checked="" type="checkbox"/>
dEL.1	limit 1 delay	<input checked="" type="checkbox"/>
L.2	lower limit 2	<input checked="" type="checkbox"/>

Simulation

Configurations that can only be implemented via the BlueControl software (not via the front-panel keys):

- Customer-specific linearizations
- Enable „forcing“ for inputs/outputs. Forcing allows to write the analog and digital inputs and outputs via Modbus interface.
- Adjustment of limits for operating hours and switching cycles
- Switch-over to 60 Hz mains frequency
- Disable operator actions and operating levels, plus password definition
- Prevent automatic optimization of cycle times T1, T2

Hardware requirements:

A PC adapter (see „Accessories“) is required for connecting the controller.

Updates and demo software can be downloaded from:
www.pma-online.de

ORDERING INFORMATION

Digital 280-1

D 2 8 0 - 1 - 0 0 - 0 0

Screw terminals

90..250V AC

0

24VAC / 18..30VDC

1

90..250V AC, 2 relays + mA/V/logic

2

24VAC / 18..30VDC, 2 relays + mA/V/logic

3

no option

0

Modbus RTU + Transmitter power supply + digital input di2, di3 (optical coupler)

1

Standard configuration

0

Configuration to specification

9

no manual

0

manual german

D

manual english

E

manual french

F

Standard (CE - certified)

0

UL-certified)

U

ACCESSORIES

Description		Order no.
PC adapter, for connecting BlueControl software to the BluePort		9407-998-00001
Standard rail adapter		9407-998-00061
Operating manual	German	9499-040-67318
Operating manual	English	9499-040-67311
Operating manual	French	9499-040-67332
BlueControl Mini	German/English/French	www.pma-online.de
BlueControl Basic	German/English/French	9407-999-11001
BlueControl Expert	German/English/French	9407-999-11011

BlueControl, versions and functions:

Functionality	Mini	Basic	Expert
parameter and configuration setting	yes	yes	yes
controller and control loop simulation	yes	yes	yes
download: writes an engineering to the controller	yes	yes	yes
online mode/ visualisation	SIM only	yes	yes
creation of user defined linearizations	yes	yes	yes
configuration of extended operating level	yes	yes	yes
upload: reads an engineering from the controller	SIM only	yes	yes
basic diagnosis function	no	no	yes
file, save engineering data	no	yes	yes
printer function	no	yes	yes
online documentation, help system	yes	yes	yes
measurement correction (calibration procedure)	yes	yes	yes
data acquisition and trend function	SIM only	yes	yes
network and multiuser licence	no	no	yes
personal assistant function	yes	yes	yes
extended simulation	no	no	yes
extended diagnostic and service functions	no	no	yes

**PMA**

Prozeß- und Maschinen- Automation GmbH

P.O. Box 31 02 29

D-34058 Kassel

Tel.: +49 - 561- 505 1307

Fax: +49 - 561- 505 1710

E-mail: mailbox@pma-online.de

Internet: <http://www.pma-online.de>

Your local representative: