

PROFIBUS-DP Slave

Cyclic transmission of up to 16 input and 16 output values

Free definition of data content

Transmission of process and parameter data

Inputs and outputs as decentral IO

Description

The PROFIBUS-DP option enables the KS 94 to be connected to PROFIBUS-DP networks. This allows de-centralized and independent industrial and process controllers to be integrated into PLC or PC systems. The PLC/IPC transfers set-points and control information to the KS 94, and polls process values cyclically.

All control functions and the associated scaling and monitoring tasks are executed independently. This ensures high process safety together with short times for engineering and commissioning.

Display and operation

Via its "day & night" display, the KS 94 shows all process data locally and easily readable. If required, one line of the display can be used to show a freely-definable message. Furthermore, the controller can be switched to local operation, e.g. for commissioning the control loop without any previous programming of the PLC or the supervisory system. In addition, the Engineering Tool ET/KS 94 is available as a useful device. It is connected via a front-panel socket of the KS 94, and serves for configuration, parameter setting, and operation of the controller. The standard graphical trend display allows a qualitative evaluation of the control results.

De-centralized I/O

Apart from the control function of the KS 94, it is possible to access all inputs and outputs directly. In this way, all the controller's I/O are also available to the PLC/IPC.

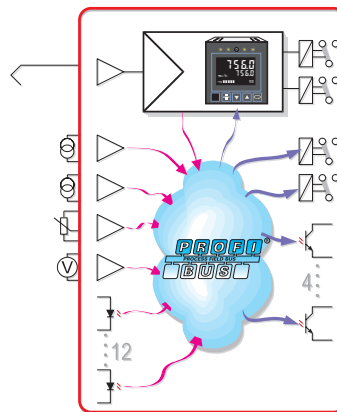

The basic functions of the KS 94 / DP, such as inputs/outputs, control functions, etc. are described in the data sheet (9498 737 28213) for the KS 94.

Technical data

According to EN 50170 Vol. 2

Reading and writing of all process data, parameters and configuration data.

Data Format

Real values such as set-points and process data are transmitted in the IEEE format (REAL) or in the 16-bit fixed point format (FIX) with one digit behind the decimal point (configurable).

Parameter Channel

Process data and selected parameter data are written and read cyclically. All process-, parameter- and configuration data can be transmitted via parameter channel. These data are transmitted over several cycles on request.

Configurable Process Data Modules

Module a (I/O):

process data			
read	process value (xeff)	write	set-point (w)
	output value (yeff)		output value (yman)
	set-point (weff)		auto/manual
	status		
no parameter channel			

Module b (I/O + parameter channel):

process data			
read	process value (xeff)	write	set-point (w)
	output value (yeff)		output value (yman)
	set-point (weff)		auto/manual
	status		
parameter channel			

Module c (extended I/O + parameter):

process data			
read	process value (xeff)	write	set-point (w)
	output value (yeff)		output value (yman)
	set-point (weff)		auto/manual
	status		outputs (OUT+do)
	inputs (INP+di)		
parameter channel			

Module d (ext. I/O + forcing + parameter):

process data			
read	process value (xeff)	write	set-point (w)
	output value (yeff)		output value (yman)
	set-point (weff)		auto/manual
	status		inputs (INP+di)
	inputs (INP+di)		
parameter channel			

Module e (variabel + para. channel):

process data			
read	status word 1+2	write	control word 1+2
	IN1...IN16		OUT1...OUT16
parameter channel			

Module f (variabel + para. channel):

process data			
read	status word 1+2	write	control word 1+2
	IN1...IN16		OUT1...OUT16
parameter channel			

Module g (multiplex transmission):

process data			
read	status word 1+2	write	control word 1+2
	Index IN (1...16)		Index OUT (1...16)
	IN		OUT
no parameter channel			

Memory requirements (byte):

Module	read		write	
	FIX	REAL	FIX	REAL
a	8	14	6	10
b	16	22	14	18
c	30	46	20	28
d	30	46	26	40
e	44	76	44	76
f	24	36	24	36
g	8	10	8	10

Writing of inputs/outputs can be activated individually for each input and output.

Data contents (Modules e,f,g)

Status words 1 and 2

- Reading the digital inputs
- Sensor break/short-circuit status
- Error and status information
- Alarms and controller outputs
- Automatic or manual operation

Control words 1 and 2

- Automatic/Manual switch-over
- Controller off/Set-point switch-over
- Forcing of digital inputs
- Forcing/enabling of digital outputs
- Local/Remote switch-over

Inputs IN1...IN16

The data to be read from the KS 94 can be defined by means of the Engineering Tool ET/KS 94 (Version 4.0 upwards). It is possible to access all signals and parameters (⇒ Fig.4).

Outputs OUT1...OUT16

The data to be transmitted to the KS 94 can be defined by means of the Engineering Tool ET/KS 94 (Version 4.0 upwards). It is possible to access all signals and parameters (⇒ Fig.4).

Functions

Enabling the controller outputs

The control word allows you to enable/disable the digital controller outputs.

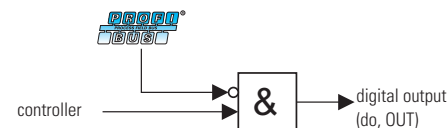

De-centralized I/O

All inputs and outputs of the KS 94 are directly accessible via the I/O memory area. In this way it is possible to make use of additional input/output functions apart from the control function. Analog values are transmitted in the scaled format.

Input forcing

All physical inputs can be overwritten via the PROFIBUS-DP. In this way it is possible e.g. to define individual elements of a multi-element control loop via the bus, or to let the PLC compute corrections for process value/set-point.

Back-up controller mode

During "normal" operation, the control output is computed by the master. The KS 94 is used to measure the process values, to generate the control output signal, and for display.

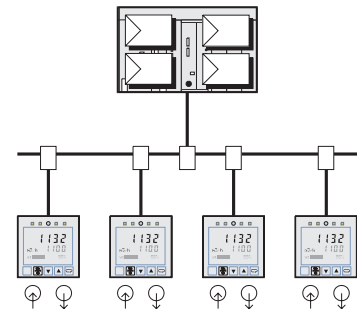

If the master or the bus communication should fail, the KS 94 takes over automatically and bumplessly.

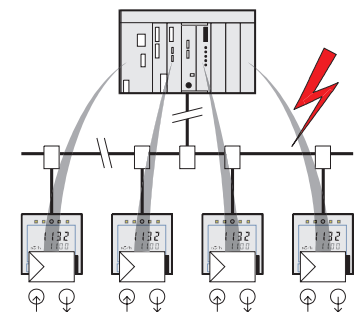

Connection

AMP flat-pin terminals 1 x 6,3 mm or 2 x 2,8 mm.

By needs of an adapter (⇒Accessories) Sub-D connectors or screw terminals can be used.

Diagnosis/behavior on error

If the master fails or the bus connection is interrupted (communication error) the last setpoint remains active and the KS 94 works independently. If the master PLC is switched in stop-mode the Clear Data Signal will be suppressed and the last setpoint remains active, too! In case of a fault on the bus, the KS 94 can activate an alarm relay.

Plain-text display on the controller front:

- Master missing
- Parameter error
- Configuration error
- Loss of master

Cable

According to EN 50170 Vol. 2

Transmission speeds and cable lengths

Automatic transmission speed detection

Speed	Max. cable length
9,6 kbit/s	1200 m
31,25 kbit/s	1200 m
45,45 kbit/s	1200 m
187,5 kbit/s	1200 m
500 kbit/s	400 m
1,5 Mbit/s *	200 m
3 Mbit/s *	100 m
6 Mbit/s *	100 m
12 Mbit/s *	100 m

* Sub-D adapter 9407-998-00031 required!

Addresses

0...126 (factory setting: 126)

Remote setting of address allowed

Other functions

Sync and Freeze

Terminating resistors

Internally selectable with wire-hook switches

Required Accessories

Engineering Set

Content:

- GSD-file
- Manual, data description
- Function blocks for Step5, Step7 used for reading and writing of parameter and configuration data via parameter channel.

Universal S5 Function Block for Parameter Channel

By needs of this FB the parameter channel can be used in P- and Q-tiles, extended P-area and together with the special function block FB IM380C.

Fig. 1 Connection diagram KS 94/DP:

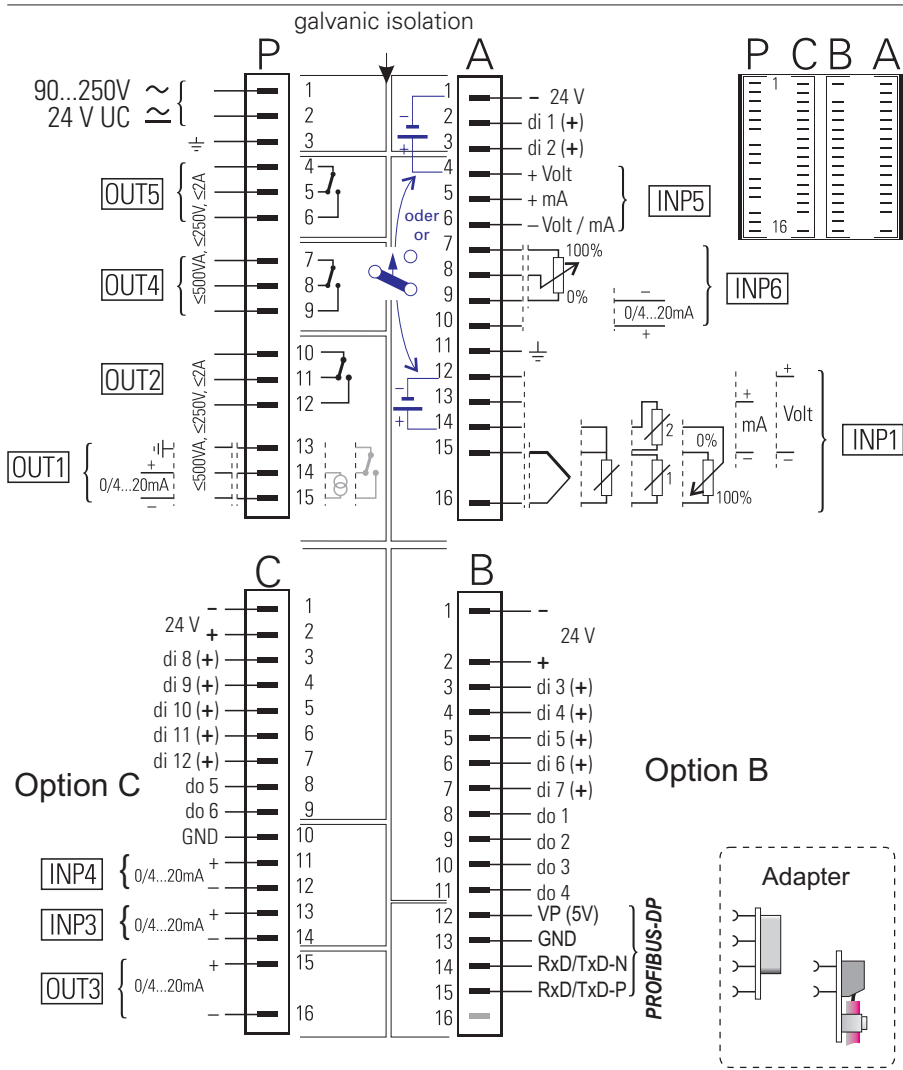

Fig. 2 Sub-D adapter:

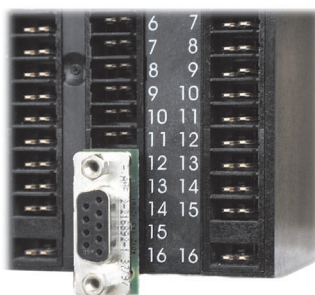

Fig. 3 Dimensions (in mm):

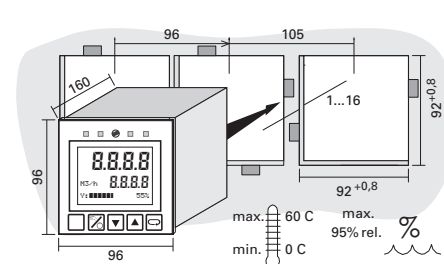
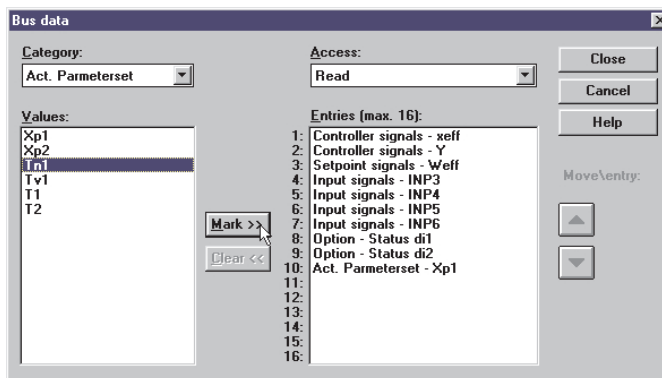

Fig. 4 Selection of data content by means of the Engineering Tool (process data module e, f, g):



ORDERING INFORMATION

9 4 0 7 9 1

↑ 2
↑ 3

KS 94

KS 94 with transmitter power supply

90...250V AC 4 relays	3
90...250V AC 3 relays + current output	4
24V UC 4 relays	7
24V UC 3 relays + current output	8
no interface	0
TTL-interface + di/do	1
RS422 + di/do + clock	2
PROFIBUS-DP + di/do	3
INTERBUS + di/do	4
no extension	0
INP3, INP4, OUT3, di/do	1
OUT3	5
no additional functions	0
measurement correction	1
measurement correction + programmer	2
Standard configuration	0
2-point controller	1
3-point controller	2
continuous controller	3
3-point controller (Logic/relays)	4
3-point stepping controller for 3-element control	5
continuous controller for 3-element control	6
configuration to specification	9

Accessory Equipment

Order no..

Engineering Set	German	9407-999-05201
Engineering Set	Englisch	9407-999-05101
Adapter, screw terminals (max. 1,5Mbit/s)		9407-998-00021
Adapter, Sub-D		9407-998-00031
Universal S5 function block for parameter channel		9407-999-05301

PMA
Prozeß- und Maschinen-
Automation GmbH
Miramstraße 87, D-34123 Kassel

Tel./Fax: +49 561 505 - 1403/-1661
E-mail: export@pma-online.de
Internet: <http://www.pma-online.de>