

**INTERBUS**

**PMA**

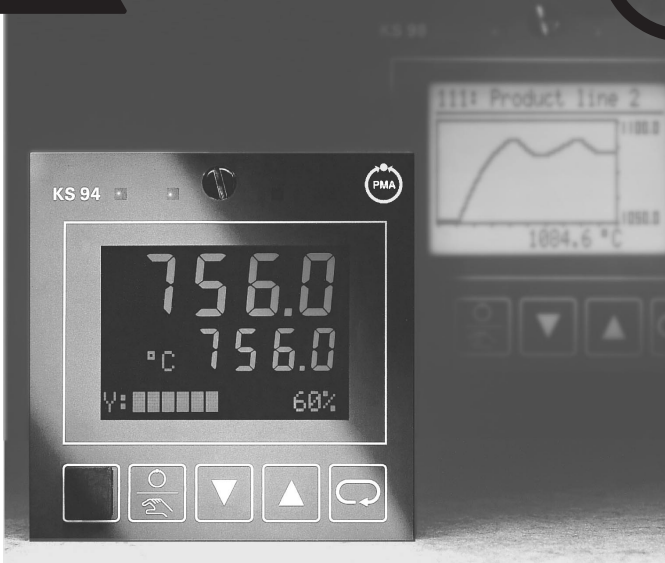

## KS 94 / IBS

### INTERBUS option for KS 94

INTERBUS remote bus

Cyclic transmission of up to 16 input and 16 output values

Free definition of data content

Transmission of process and parameter data

Inputs and outputs as decentral IO

#### **Description**

The INTERBUS option enables the KS 94 to be connected to INTERBUS networks. This allows de-centralized and independent industrial and process controllers to be integrated into PLC or industrial PC systems. The PLC/IPC transfers set-points and control information to the KS 94, and polls the process values cyclically.

All control functions and the associated scaling and monitoring tasks are executed independently. This ensures high process safety together with short times for engineering and commissioning.

#### **Display and operation**

Via its "day & night" display, the KS 94 shows all process data locally and easily readable. If required, one line of the display can be used to show a freely-definable message. Furthermore, the controller can be switched to local operation, e.g. for commissioning the control loop without any previous programming of the PLC or the supervisory system. In addition, the Engineering Tool ET/KS 94 is available as a useful device. It is connected via a front-panel socket of the KS 94, and serves for configuration, parameter setting, and operation of the controller. The standard graphical trend display allows a qualitative evaluation of the control results.

#### **De-centralized I/O**

Apart from the control function of the KS 94, it is possible to access all inputs and outputs directly. In this way, all the controller's I/O are also available to the PLC/IPC.

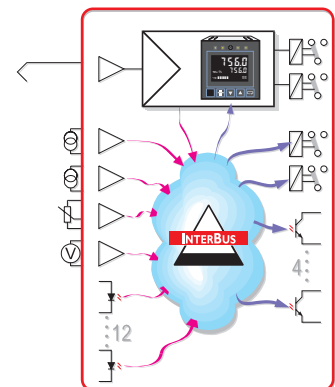

The basic functions of the KS 94 / IBS, such as inputs/outputs, control functions, etc. are described in the data sheet (9498 737 28213) for the KS 94.

## Technical data

INTERBUS interface according to EN 50 252, Vol. 2  
Remote 4-wire RS 485 bus

### Data format

Real values such as process values and set-points are transmitted in a 16-bit format with a fixed decimal point (FIX) for one decimal digit.

### Process data channel

The process data channel (PD) can be structured differently in terms of length and contents:

#### Structure A

without PCP: Ident code = 51, PDL=64 bit  
with PCP: Identcode = 240, PDL = 64 bit  
Transmission of digital and analog values directly via the I/O memory area.

Byte	KS 94 ⇔ INTERBUS	INTERBUS ⇔ KS 94
0 1	Status word 1	Control word 1
2 3	Status word 2	Control word 2
4 5	IN 1	OUT 1
6 7	IN 2	OUT 2

#### Structure B

Identcode = 240, PDL = 128 bit  
Transmission of digital and analog values directly via the I/O memory area.

Byte	KS 94 ⇔ INTERBUS	INTERBUS ⇔ KS 94
0 1	Status word 1	Control word 1
2 3	Status word 2	Control word 2
4 5	IN 1	OUT 1
6 7	IN 2	OUT 2
8 9	IN 3	OUT 3
10 11	IN 4	OUT 4
12 13	IN 5	OUT 5
14 15	IN 6	OUT 6

#### Structure C

Identcode = 51, PDL = 48 bit  
Multiplexed transmission of digital and analog values.

Byte	KS 94 ⇔ INTERBUS	INTERBUS ⇔ KS 94
0 1	Status word 1	Control word 1
2 3	Index Read Index Write	Index Read Index Write
4 5	Val Read	Val Write

It is possible to address max. 16 values (analog values or status bytes) via "Index Read" and "Index Write" respectively.

## Data contents

### Status words 1 and 2

- Reading the digital inputs
- Sensor break/short-circuit status
- Error and status information
- Alarms and controller outputs
- Automatic or manual operation

### Control words 1 and 2

- Automatic/Manual switch-over
- Controller off/Set-point switch-over
- Forcing of digital inputs
- Forcing/enabling of digital outputs
- Local/Remote switch-over

### Inputs IN1...IN16

The data to be read from the KS 94 can be defined by means of the Engineering Tool ET/KS 94 (Version 4.0 upwards). It is possible to access all signals and parameters.

### Outputs OUT1...OUT16

The data to be transmitted to the KS 94 can be defined by means of the Engineering Tool ET/KS 94 (Version 4.0 upwards). It is possible to access all signals and parameters.

## Functions

### Enabling the controller outputs

The control word allows you to enable/disable the digital controller outputs.

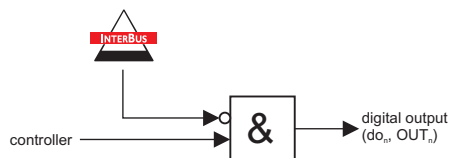

### De-centralized I/O

All inputs and outputs of the KS 94 are directly accessible via the I/O memory area. In this way it is possible to make use of additional input/output functions apart from the control function. Analog values are transmitted in the scaled format.

### Input forcing

All physical inputs can be overwritten via the INTERBUS. In this way it is possible e.g. to define individual elements of a multi-element control loop via the bus, or to let the PLC compute corrections for process value/set-point.

### Back-up controller mode

During "normal" operation, the control output is computed by the master. The KS 94 is used to measure the process values, to generate the control output signal, and for display.

If the master or the bus communication should fail, the KS 94 takes over automatically and bumplessly.

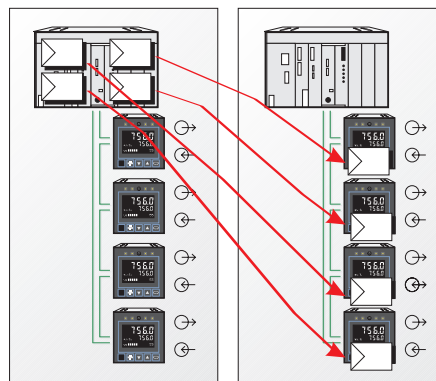

## Connection

Bus connection via rear D-type connectors.

- Incoming bus: male
- Outgoing bus: female

## Cable

Cable according to EN 50 254-2-2  
Max. 400 m of cable are permitted between two remote bus participants.

## Diagnosis/behavior on error

If the master fails or the bus connection is interrupted (communication error) the last setpoint remains active and the KS 94 works independently. In case of a fault on the bus, the KS 94 can activate an alarm relay.

INTERBUS diagnostic LEDs on the rear (→ Fig. 1).

Plain-text display on the controller front:

- Unknown module
- No connection
- Bus ready

Certification: in preparation  
PCP channel: in preparation

## Permissible temperatures

For specified accuracy: 0...50°C  
For operation: 0...55°C  
Storage and transport: -20...60°C

Fig. 2 Connection diagram KS 94/IBS:

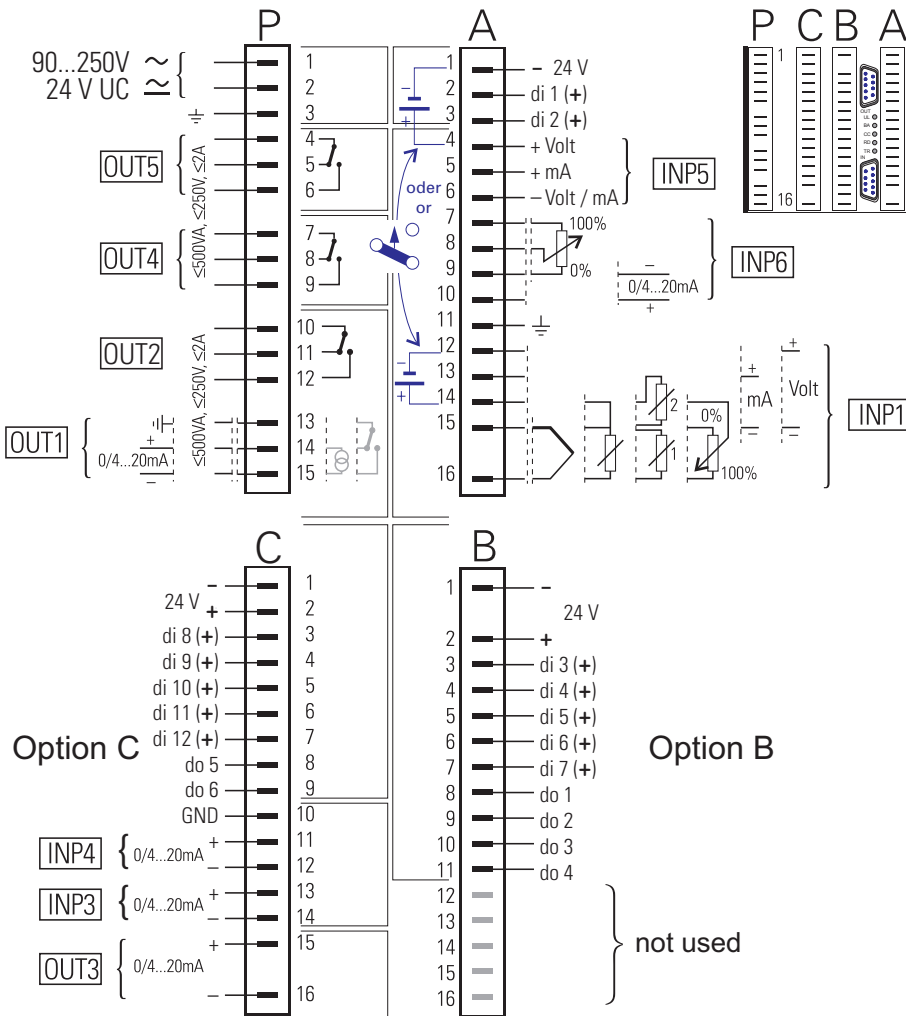

Fig. 4 KS 94 in CMD:

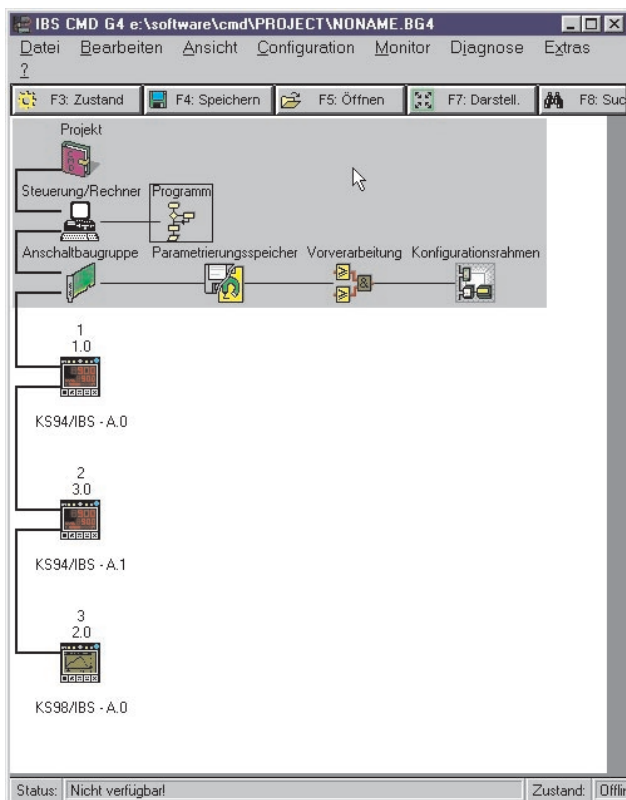

Fig. 1 Connection and LEDs INTERBUS

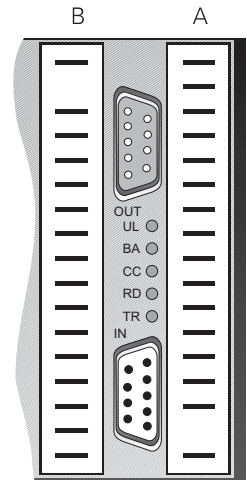
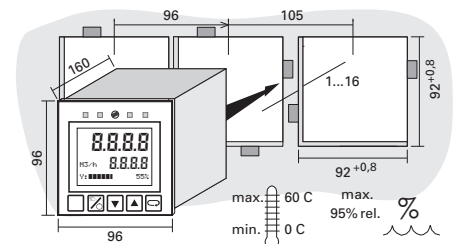

Fig. 3 Dimensions (in mm):



## ORDERING INFORMATION

9 4 0 7 9     1

↑ 2 ↑ ↑ ↑ ↑

### KS 94

#### KS 94 with transmitter power supply

90...250V AC 4 relays	3
90...250V AC 3 relays + current output	4
24V UC 4 relays	7
24V UC 3 relays + current output	8
no interface	0
TTL-interface + di/do	1
RS422 + di/do + clock	2
PROFIBUS-DP + di/do	3
<b>INTERBUS + di/do</b>	<b>4</b>
no extension	0
INP3, INP4, OUT3, di/do	1
OUT3	5
no additional functions	0
measurement correction	1
measurement correction + programmer	2
Standard configuration	0
2-point controller	1
3-point controller	2
continuous controller	3
3-point controller (Logic/relays)	4
3-point stepping controller for 3-element control	5
continuous controller for 3-element control	6
configuration to specification	9

### Accessory Equipment

### Order no.

Engineering Set ES/KS94 INTERBUS	german	9407-999-10111
Engineering Set ES/KS94 INTERBUS	english	9407-999-10101

Engineering Set consists of the manual for INTERBUS and a diskette with all required files for CMD.

PMA  
 Prozeß- und Maschinen- Automation GmbH  
 Miramstraße 87  
 D-34123 Kassel  
 Tel. (0561) 505 - 1307  
 Fax: (0561) 505 - 1710  
 mailbox@pma-online.de  
 Internet: <http://www.pma-online.de>