

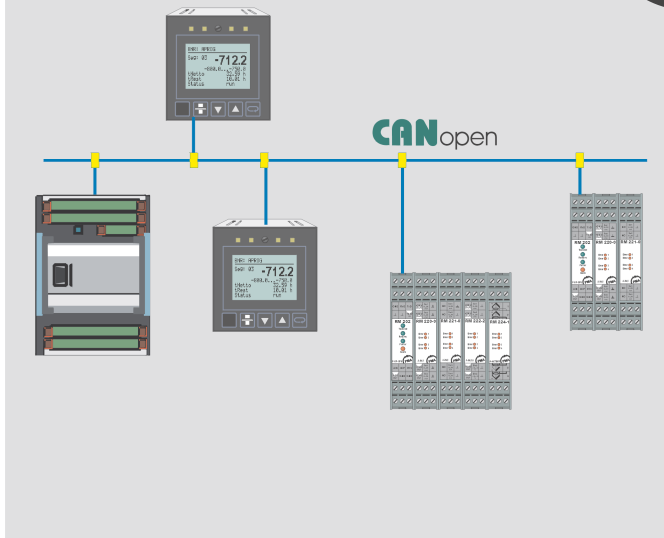

KS 98+

I/O extension with CANopen



CANopen protocol

I/O extension with RM 200

Communication links to other KS 98+

Connection of the multi-temperature controllers KS 800 und KS 816

Fully supported by ET/KS 98plus

No network configurator required

PROFILE

De-centralized automation islands reduce investment costs and provide better transparency. Because the KS98 and KS98+ can be connected to established field busses such as PROFIBUS or InterBus, it is possible to implement logical and geographically distributed automation concepts with local facilities for operation and visualization.

By adding an additional CANopen interface, the standard version of the multi-function unit KS98+ offers:

- facilities for local I/O extension by means of PMA's modular I/O system RM200
- connection to PMA's multi-temperature controllers KS 800 / KS 816 with CANopen interface
- local data exchange with other KS98+ units (cross-communication).

If required, other sensors, actuators, transmitters, sequence control devices, machines, etc. can be connected via the CANopen protocol.

DESCRIPTION

One KS98+ is configured as the master unit (NMT; Network Management) of a local CAN network. During start-up, this master calls the general network services and configures all the connected CAN nodes (slaves), e.g. process data objects (PDO), communication and parameters.

In this way, a special CAN network configurator is not required. Apart from the NMT master, up to 5 other CAN nodes can be connected (RM 200; KS 800/ KS 816; KS 98).

By means of the Engineering Tool „ET/KS98plus“, the corresponding node and data functions are implemented in the CAN master (block numbers 21...25). The node function provides the link between the connected slave devices (RM 200, KS98, KS 800/KS 816) and the data functions of the master.

Cyclic data transmission is only triggered when a process value changes. During transmission, the following checks are performed:

- ✓ is there an engineering error (et_err), e.g. if several node functions refer to the same CAN address,
- ✓ does the expected subscriber answer from the specified CAN address (id_err), and
- ✓ are the received process values valid (valid).

Corresponding status signals can be evaluated in the Engineering of the KS98+.

I/O EXTENSION WITH RM 200

The RM 200 node function provides a communication port for every I/O module socket in the RM 200 basic module. This port is wired according to the data functions of the relevant type of I/O.

The data functions make the received process values available at their outputs for further processing by the Engineering. Conversely, the process values originating from the Engineering are transferred to the node functions for outputting via the RM200 modules. The I/O numbering corresponds to that of the RM modules. Configuration of the RM 200 modules is done via the parameter dialog of the ET/KS 98plus. Node functions are computed every 100 ms, and data functions according to the selected time group.

CONNECTION OF KS 800/KS 816

The multi-temperature controllers have 8 (KS 800) or 16 channels (KS 816). The KS 8xx node function provides sixteen communication outputs, each of which represents a controller channel. In addition to the checks mentioned above (et_err, id_err, valid), the following status values are signalled:

- KS 8xx available (online)
- Monitoring of the digital outputs do1...do12 (fail1) and do13...do16 (fail2)
- Short-circuited heating current (fail3)
- Status of the control inputs di1...di4.

Up to sixteen data functions are connected to the node function, that provide the following process values for a controller channel (A/B):

Received from von KS 800/KS 816

- Process value x
- Output variable y
- Status words St1 and St2
- Sensor fault xf

Transmitted to KS 800/KS 816

- Status „Auto/Manual“ a/m
- Status „Controller disabled“ off
- Set-point switch-over w/W2
- Set-point switch-over int/ext
- Start of self-tuning Ostart

The status words St1 and St2 contain the following reply messages per channel, that can be polled individually via an analog/binary converter (ABIN):

- Status word St1
 - Alarms HH, H, L, LL
 - Sensor fault
 - Heating current fault
 - Leakage current fault
 - Common alarm for digital outputs
- Status word St2
 - Set-point W2 enabled
 - Set-point Wint enabled
 - Start-up set-point enabled
 - Self-tuning enabled
 - Fault during self-tuning
 - Controller in manual mode
 - Controlled disabled

CROSS-COMMUNICATION

Although the exchange of data between the RM 200/KS 8xx and the slave KS98+ must be done exclusively via the master, direct „cross-communication“ is possible.

With cross communication, data exchange between several KS98+ in a CAN network is done by means of transmission modules (CSEND; block nos. 21/23/25/27) and receive modules (CRCV; block nos. 22/ 24/ 26/ 28), that are installed into the relevant Engineering with the ET/KS98plus.

Every transmission/receive module is able to transfer up to 9 analog values and 16 digital states from the relevant Engineering. The transmitter sends the data together with its node address and the block number.

The receiver checks whether the message corresponds with the specified transmitter address, and if the block number of the transmitter is lower by „1“ than its own.

Fig. 1: Local I/O extension with link to superordinate systems

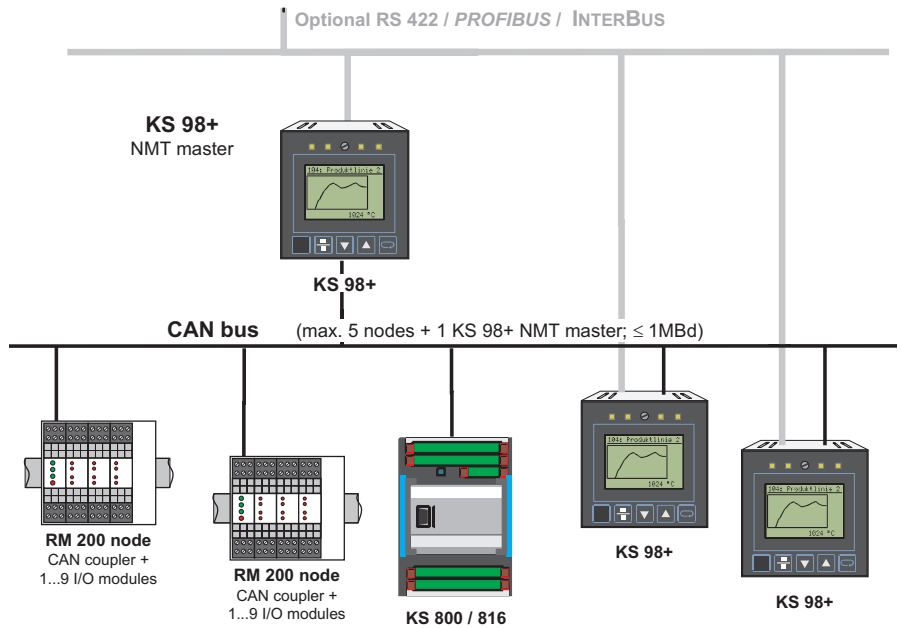

Fig. 2: Partial engineering for data exchange with KS 800 / 816

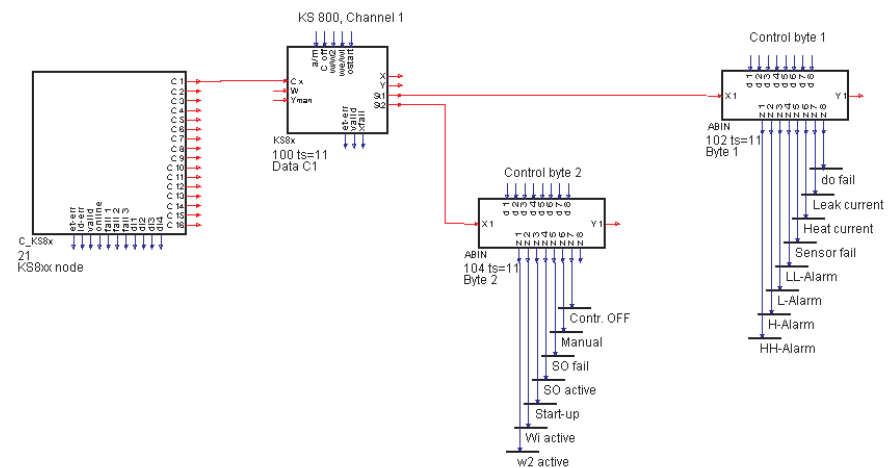

Fig. 3: Partial engineering for data exchange with a RM module

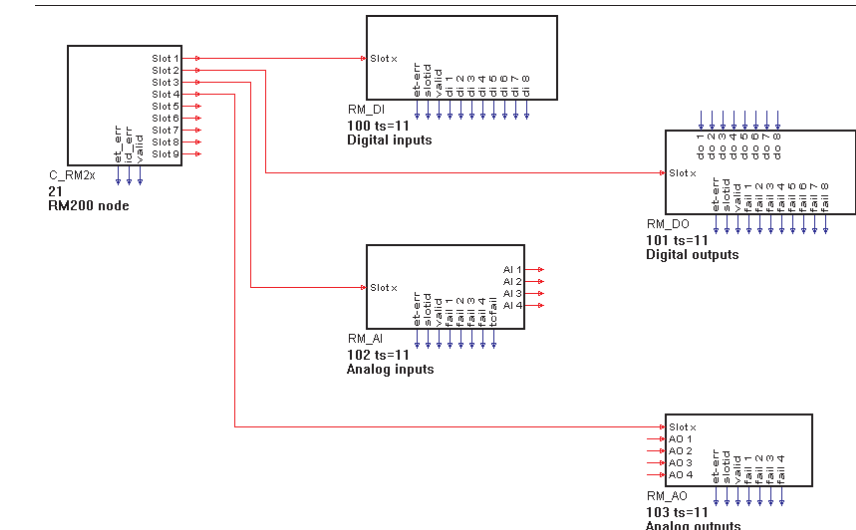
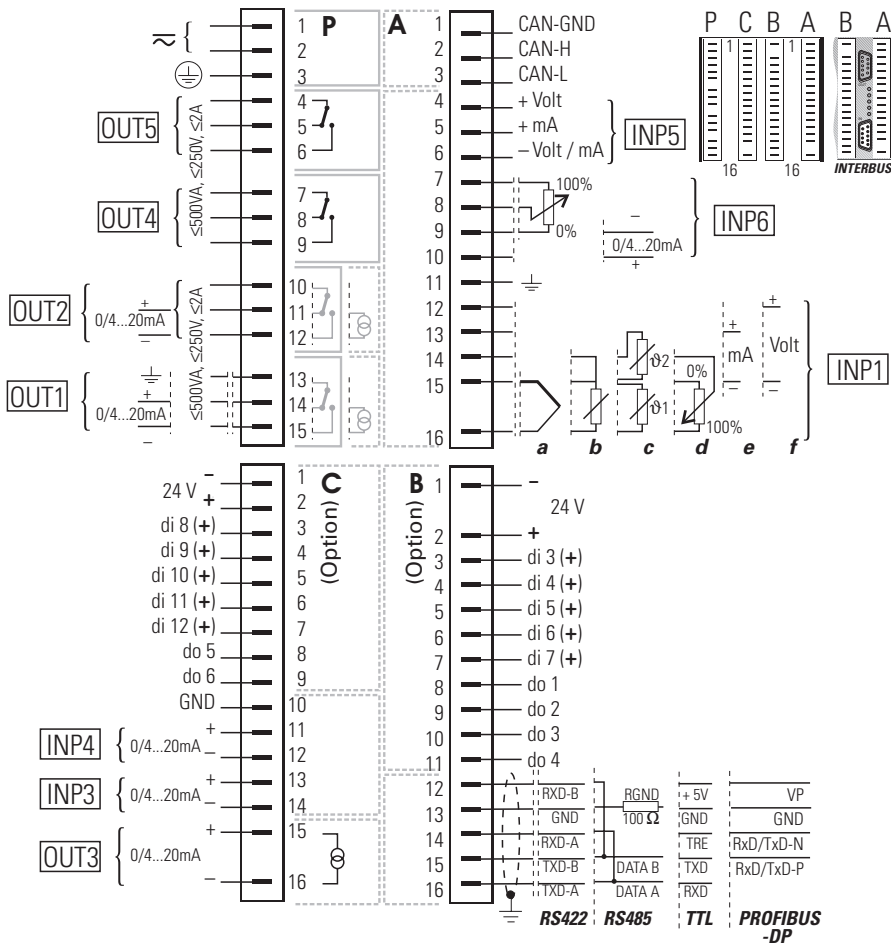

Fig. 4: Connecting diagram KS 98+



TECHNICAL DATA

Detailed technical data and functional descriptions are given in the following data sheets:

- KS 98: 9498 737 32113
- KS 800: 9498 737 31713
- KS 816: 9498 737 35913
- RM 200: 9498 737 37813

CANopen master:

1 x KS 98+ (NMT master; CAN manager) and ≤ 5 CAN slaves (RM 200, KS 98+ or KS 800/KS 816; any combination)

Transmission speed:

10 / 20 / 50 / 100 / 125 / 250 / 500 / 800 / 1000 kbaud (depends on cable length), selectable via Engineering Tool.

Recommendation for max. System-configuration (1 Master + 5 Slaves): ≥ 250 kbaud / bus length ≤ 250m !

Bus length

≤ 1000 / 1000 / 1000 / 500 / 250 / 250 / 100 / 50 / 25 m, depends on selected transmission speed.

Transmission mode: cyclical

Transmission time:

Depending on the selected transmission speed and the number of CAN nodes.

- RM 200 ↔ KS 98+: 100ms
- KS 98+ ↔ KS 98+: ≥ 200ms
- KS 800/816 ↔ KS 98+: 1,6 / 3,2s (200ms per channel)

Error detection:

Automatic node monitoring (node guarding).

Node address

- KS 98+: 1...24 (Default =1)
- KS 800/ KS 816: 2...42 (Default =2)
- RM 200: 2...42 (Default =32)

Fig. 5: Communication functions in the KS 98+

Block no.	RM 200 CN_RM2x	KS800 / 816 CN_KS8x	KS 98+ CSEND	KS 98+ CRCV
↓	<i>Alternative functions !</i>			
21	x	x	x	-
22	x	x	-	x
23	x	x	x	-
24	x	x	-	x
25	x	x	x	-
26	-	-	-	x
27	-	-	x	-
28	-	-	-	x

With CAN master only !

Fig. 6: Overall dimensions

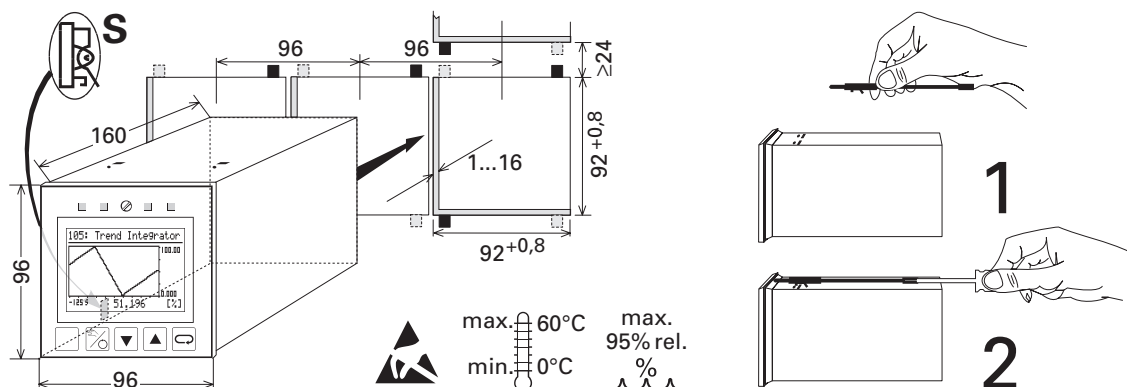

ORDERING DATA KS 98+

		9	4	0	7	9					1
BASIC UNIT	{	KS 98 with CANopen I/O									
POWER SUPPLY AND PROCESS OUTPUTS	{	90...250V AC 4 relays									
	{	90...250V AC 2 relays + 2 current outputs									
	{	24V UC, 4 relays									
	{	24V UC, 2 relays+ 2 current outputs									
OPTION B INTERFACE	{	no interface									
	{	TTL-interface + di/do									
	{	RS422 + di/do + Uhr									
	{	PROFIBUS DP + di/do									
OPTION C (standard)	{	no extensions									
	{	INP3, INP4, OUT3, di/do									
	{	INP3 (mV), INP4, OUT3, di/do									
SETTING	{	Basic structure									
	{	Standard configuration									
	{	Customer-specific configuration									

Max. system configuration with RM 200

≤16 analog inputs and ≤16 analog outputs per RM200 basic module !

Max. no. of I/Os per basic module:
 ≤72 digital inputs/outputs (without analog modules !), or
 ≤16 analog inputs, ≤16 analog outputs and ≤8 digital I/O per basic module; (any combination within the limits).

Electrical connections

See connecting diagram.
 Note: Control inputs di1 and di2 are not available !

Galvanic isolation

Galvanically isolated groups of terminals are marked in the connecting diagram Fig.4.

Signal and measurement circuits

Working voltage: ≤ 50 Vr.m.s. against ground; according EN 61010 (for functional reasons; dotted lines).

Mains circuits 90...250 VAC

Working voltage: ≤ 300 Vr.m.s. against each other and against ground; according EN 61010 (for safety reasons; full lines).

ORDERING DATA RM 200 (supported modules)

Bus coupler modules

RM 201 CANopen coupler 9 4 0 7 7 3 8 2 0 1 0 1

Basic Modules

RM 211 Basic module 3 slots 9 4 0 7 7 3 8 2 1 1 0 1

RM 212 Basic module 5 slots 9 4 0 7 7 3 8 2 1 2 0 1

RM 213 Basic module 10 slots 9 4 0 7 7 3 8 2 1 3 0 1

RM 214 Dummy panel 9 4 0 7 7 3 8 2 1 4 0 1

Analog Inputs

RM 221-0 Analog inputs 4 x I 9 4 0 7 7 3 8 2 2 1 0 1

RM 221-1 Analog inputs 4 x U 9 4 0 7 7 3 8 2 2 1 1 1

RM 221-2 Analog inputs 2 x I, 2 x U 9 4 0 7 7 3 8 2 2 1 2 1

RM 222-0 Analog inputs 4 x I, transm. supply 9 4 0 7 7 3 8 2 2 2 0 1

RM 222-1 Analog inputs 4 x U/Poti, transm. supply 9 4 0 7 7 3 8 2 2 2 1 1

RM 222-2 Analog inputs 2 x I, 2 x U/Poti, transm. supply 9 4 0 7 7 3 8 2 2 2 2 1

RM 224-0 Analog inputs 2 x TC, galv. isolated 9 4 0 7 7 3 8 2 2 4 0 1

RM 224-1 Analog inputs 4 x TC, Pt100 9 4 0 7 7 3 8 2 2 4 1 1

RM 224-2 Analog inputs 1 x TC, 1 x mV, galv. isolated 9 4 0 7 7 3 8 2 2 4 2 1

Analog Outputs

RM 231-0 Analog outputs 4 x I/U(+10V) 9 4 0 7 7 3 8 2 3 1 0 1

RM 231-1 Analog outputs 4xI / 2 x U(+10V), 2 x U(±10V) 9 4 0 7 7 3 8 2 3 1 1 1

RM 231-2 Analog outputs 4 x I/U (±10V) 9 4 0 7 7 3 8 2 3 1 2 1

Digital Inputs

RM 241 Digital inputs 4 x 24V DC 9 4 0 7 7 3 8 2 4 1 0 1

RM 242 Digital inputs 8 x 24V DC 9 4 0 7 7 3 8 2 4 2 0 1

RM 243 Digital inputs 4 x 230V AC 9 4 0 7 7 3 8 2 4 3 0 1

Digital Outputs

RM 251 Digital outputs 8 x 24V DC/0,5A 9 4 0 7 7 3 8 2 5 1 0 1

RM 252 Digital outputs 4 x relays230V AC, 5A 9 4 0 7 7 3 8 2 5 2 0 1

ENGINEERING TOOL

The functionality described above can be used with the following tools:
 ET/KS 98plus: version ≥4.0
 SIM/KS 98: version ≥4.0



PMA

Prozess- und Maschinen- Automation GmbH
 P.O Box 31 02 29
 D - 34058 Kassel
 Tel.: +49 - 561 - 505 1307
 Fax: +49 - 561 - 505 1710
 E-mail: mailbox@pma-online.de
 Internet: http://www.pma-online.de

Your local representative