

KS 98 Multi-function unit

- All automation functions in one unit
- Point-matrix display for visualization
- Mini PLC, computing, controlling, programmer
- Numerous analog and digital I/O
- Graphical Engineering Tool
- Library with more than 100 different functions
- Protection mode IP 65
- Front and rear interface ports

PROFILE

The KS 98 is a compact automation device, whose functions are freely structurable by means of function blocks. This enables multi-input control operations, sequence functions and complex mathematical computations to be performed. Depending on its configuration, the KS 98 can be operated as PLC, controller, programmer, or data logger.

The unit provides the operating facilities for all of these alternatives as standard. Trend and bargraph displays, plus input/output masks for analog and digital signals are the basis for simple, confident operation of plants and processes.

For several frequently-used standard applications, predefined controller options are available. They only need to be configured and have their parameters set via the front-panel keys.

DESCRIPTION

Inputs and outputs

Input INP1 is designed as a universal input for direct connection of all conventional sensors and standard signals. All other analog inputs are dedicated for current, voltage or potentiometer signals.

Galvanically isolated areas are marked in the connecting diagram (Fig. 8). All digital I/O are designed for 0/24 V signal levels, and have opto-coupler isolation.

Signal processing

Every KS 98 contains a library of functions, from which up to 350 can be selected, combined, configured and have their parameters set with the software Engineering Tool. Signal processing within the KS 98 is executed in true engineering units, so that debugging and possible extensions to the configuration are easily carried out.

In addition, there are functions available for I/O processing and for communication via the interface. Depending on version, supplementary functions are available, e.g. a „real-time clock“ for controlling the optional timer.

Functions

The functions of the KS 98 are computed and executed within fixed time groups of 100, 200, 400 or 800 ms. The individual time groups and the sequence of execution are defined with the Engineering Tool.

Signal conversion and output

The outputs of the KS 98 are controlled via the functions AOUT and DIGOUT. By connecting (soft wiring) the selected functions with these output functions, the computed values are routed to the respective output terminals.

Serial interfaces

By means of „soft wiring“, any configured data can be sent to an interface. The front interface is always fitted. It is not bussable, but is used to connect the PC with the Engineering Tool.

The rear bus interface is optional and can be used for networking the KS 98 within an automation system.

GALVANIC ISOLATION

Galvanically isolated groups of terminals are marked in the connecting diagram Fig.8.

Signal and measurement circuits

Isolation of working voltages up to 50 Vr.m.s. against ground according EN 61010 (for functional reasons; dotted lines).

Mains circuits 90 ... 250AC

Isolation of working voltages up to 300 Vr.m.s. against each other and against ground according EN 61010 (for safety reasons; full lines).

FUNCTION LIBRARY

Max. 350 functions are available. Every function needs a certain amount of working memory and a certain amount of computing time.

Survey

Scaling and computing:

in %		Time	Memory
ABSV	Absolute value	0,2	0,2
ADSU	Adding/Subtracting	0,5	0,3
SORT	Square rooting	0,4	0,2
SCAL	Scaling	2,2	0,2
MUDI	Multiplying/Dividing	0,5	0,3
LG10	Decimal Logarithm	1,0	0,2
LN	Natural Logarithm	1,0	0,2
10EXP	10 ^x	2,0	0,2
EEXP	e ^x	1,0	0,2

Limits and limit values:

in %		Time	Memory
ALLP	Limit signalling & adjustment	0,4	0,3
ALLV	Limit signalling & adjustment, variable limits	0,4	0,3
EQUAL	Comparison	0,3	0,2
VELO	Limiting rate of change	0,3	0,3
ALARM	Limit signalling with suppression during start-up	0,2	0,3
LIMIT	Limit signaller with 8 trigger points	0,6	0,4

Non-linear functions:

in %		Time	Memory
GAP	Dead zone	0,2	0,2
CHAR	Linearization with 10 segments (cascadable)	0,5	0,5

Timing functions:

in %		Time	Memory
LEAD	Differentiator	0,4	0,3
INTE	Integrator	0,5	0,3
LAG1	1st-order filter	0,3	0,2
FILT	Filter with tolerance band	0,4	0,2
DELA1	Delay time (triggerable)	0,4	1,9
DELA2	Delay time	0,4	1,9
TIMER	Timer (needs real-time clock option)	0,3	0,2
TIME2	Delay for digital signals	0,2	0,2

Logical and PLC functions

in %		Time	Memory
AND	logical AND	0,1	0,2
OR	logical OR	0,1	0,2
NOT	Negation	0,1	0,2
EXOR	Exclusive OR	0,1	0,2
FLIP	Flip-Flop	0,1	0,2
MONO	Mono-Flop	0,5	0,3
TIME1	Timer	0,4	0,2
STEP	Sequencer	0,4	0,3
BOUNCE	De-bouncer for contact inputs	0,1	0,2

Controller and programmer:

in %		Time	Memory
CONTR	Controller (incl. Operating display)	5,8	3,1
CONTR+	Controller with 6 parameter sets (incl. operating display)	5,8	3,5
APROG	Analog programmer. Max. 99 recipes (incl. operating display)	2,9	3,2
APROGD	Data module for analog programmer (10 segments)	0,6	0,5
DPROG	Digital programmer (incl. operating display)	2,8	3,1
DPROGD	Data module for digital programmer (10 segments)	0,6	0,5

Signal processing:

in %		Time	Memory
PULS	Analog/pulse converter	0,5	0,2
COUN	Counter	0,3	0,3
ZOF3	2-out-of-3 selection	0,7	0,3
MEAN	Mean-value generation	0,5	0,9
ABIN	Analog to binary	0,4	0,3
TRUNC	Whole number	0,1	0,2

Selection and storage:

in %		Time	Memory
EXTR	Min/max value selection	0,3	0,2
PEAK	Peak value storage	0,1	0,2
TRST	Sample-and-hold amplifier	0,1	0,2
SELC	Constants selection via binary signals	0,1	0,3
SELP	Parameter selection via binary signals	0,1	0,3
SELV1	Variable selection via binary signals (1 of 4)	0,1	0,2
SELV2	Variable selection via analog signal (1 of 4)	0,2	0,2
SOUT	Allocation to an output (1 of 4)	0,1	0,2
REZEPT	Saving/loading a recipe	0,5	0,5
SAFE	Setting the outputs in case of fault	0,2	0,5

Trigonometric functions:

in %		Time	Memory
SIN	Sine	1,1	0,2
COS	Cosine	1,2	0,2
TAN	Tangent	1,1	0,2
COT	Cotangent	2,0	0,2
ARCSIN	Arc sine	1,1	0,2
ARCCOS	Arc cosine	1,1	0,2
ARCTAN	Arc tangent	1,1	0,2
ARCCOT	Arc cotangent	1,2	0,2

Supplementary functions:

in %		Time	Memory
CONST	Constant value storage	0,1	0,5
STATUS	Internal status information	0,6	0,3

Display and operation:

in %		Time	Memory
VTREND	Trend display of 100 values	0,7	1,2
VBAR	Bargraph display (vertical or horizontal)	0,2	0,7
VWERT	Entry and display of 6 analog and 6 digital values	0,3	1,7
VPARA	Entry and display of 6 parameters	0,2	1,1
LED	Control of front-panel LEDs	0,1	0,2
INFO	Zeigt einen von 12 frei konfigurierbaren Texten	0,1	0,9

Interface:

in %		Time	Memory
L1READ	Reading of 7 analog and 12 digital values (ISO 1745)	0,1	0,4
L1WRIT	Writing of 8 analog and 15 digital values (ISO 1745)	0,2	0,4
DPREAD	Reading of 6 analog and 16 digital values (PROFIBUS-DP)	0,2	0,4
DPWRIT	Writing of 6 analog and 16 digital values (PROFIBUS-DP)	0,4	0,2

DETERMINATION OF CAPACITY

In order to check whether a particular application is possible with the KS 98, the quantity and type of inputs/outputs, the number of required functions, and the corresponding memory requirements must be determined roughly.

Ein-/Ausgänge

Scanning times	
INP1	200 ms
INP3, INP4	100 ms
INP5	800 ms
INP6	400 ms
di1...di12	100 ms
OUT1...OUT4	100 ms
di1...do6	100 ms

Determining computing capacity

Computation of the function blocks is executed in „time slots“ of fixed duration, the cycle time T_r .

The cycle time is defined by selecting a particular „time group“. Thus, the relevant function block will be executed in every time slot (every 100 ms), in every second time slot (every 200 ms), etc. For every time slot, a net computing time (= 100 %) is available. Because each function requires a certain amount of computing time, the sum of all the functions in a time slot must not exceed 100 % of the available time.

Operation and display

All configuration, parameter setting and operational data of the selected function blocks can be changed via the front-panel keys of the KS 98. For commissioning, the input and output values can be displayed.

Operating displays

Operation of a controller needs a different display than operation of a programmer. With its point-matrix display, the KS 98 is ideally suited for such different displays. Switching between the displays is always possible.

Disabling

Depending on the application, different demands are placed on the disabling functions for operation, parameter setting, or configuration. Disabling can be controlled via the digital inputs, by means of internal wire-hook switches, by a defined internal status, or with access codes. Typically, the entire operating level, parameter adjustment and configuration, or the operation of certain functions can be disabled.

Engineering Tool ET/KS98plus

In principle, the Engineering Tool for the KS 98 consists of a function block editor, based on the international IEC 1131-3 standard.

Functions

- Functions are selected from menus, and placed in the working area of the PC's display.
- Graphical connections between inputs and outputs.
- If a function is moved on the screen, its connections are maintained automatically.
- Configuration and parameter setting of the functions.
- Down-loading the completed program to the KS 98.
- Management of all adjustments and settings.
- Connection to PC via front-panel interface (PC adapter required).
- If the connection is made via the rear bus interface, an RS 232, RS 422/485 adapter, and possibly an interface adapter are necessary.
- The manual of the KS 98 is part of the Help system.

Fig. 1 Example of an engineering for the KS 98

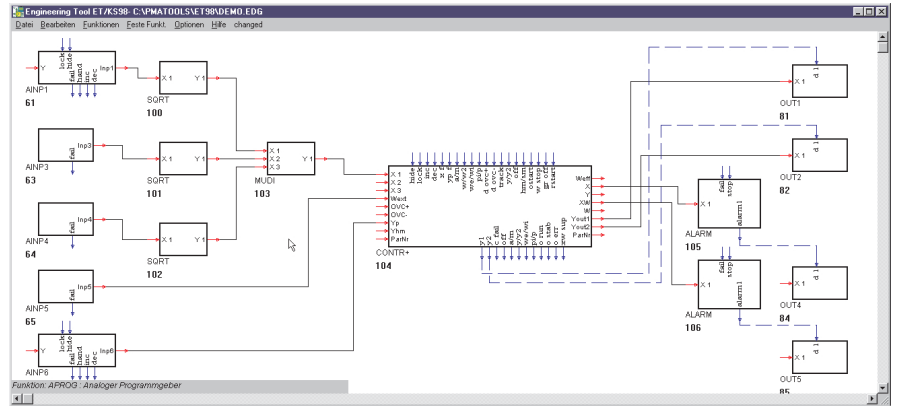

Fig. 2 Operating display for a controller (CONTR, CONTR+)

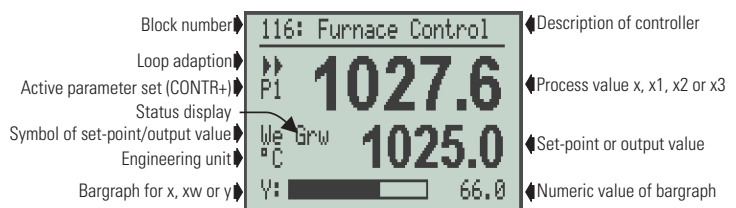

Fig. 3 Operating display for an analog programmer (APROG)

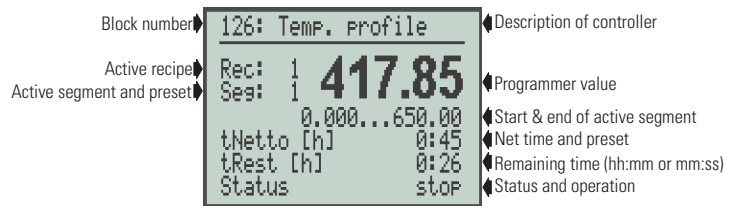

Fig. 4 Entry and display of 6 analog and binary values (VWERT)

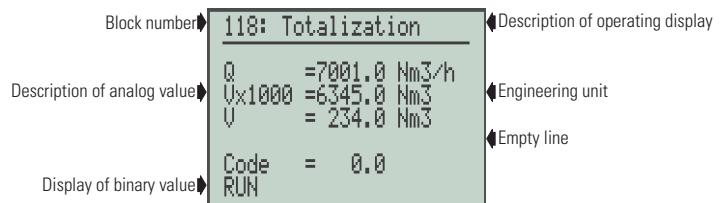

Fig. 5 Trend display (VTREND)

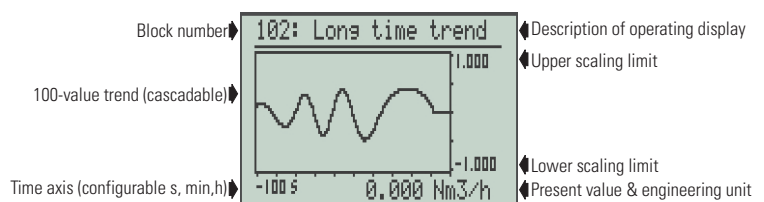
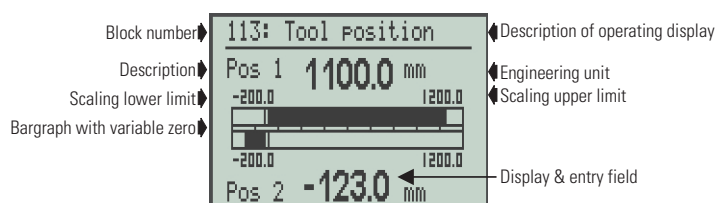

Fig. 6 Horizontal bargraph display (VBAR)



TECHNICAL DATA

INPUTS

Depending on version and selected options, the following inputs and outputs are available:

	DI	DO	AI	AO
STANDARD (4 relays)	di1 di2	OUT1 OUT2 OUT4 OUT5	INP1 INP5 INP6	-
oder				
STANDARD (2 relays + 2AO)	di1 di2	OUT4 OUT5	INP1 INP5 INP6	OUT1 OUT2
OPTION B (additional)	di3 di4 di5 di6 di7	do1 do2 do3 do4	-	-
OPTION C (additional)	di8 di9 di10 di11 di12	do5 do6	INP3 INP4	OUT3

Universal input INP1

Limiting frequency: 1 Hz
Measurement cycle: 200 ms

Thermocouples

according to DIN IEC 584

Type	Range	Error	Resolution
L	-200...900°C	≤ 2 K	0,05 K
J	-200...900°C	≤ 2 K	0,05 K
K	-200...1350°C	≤ 2 K	0,072 K
N	-200...1300°C	≤ 2 K	0,08 K
S	-50...1760°C	≤ 3 K	0,275 K
R	-50...1760°C	≤ 3 K	0,244 K
B ⁽¹⁾	(25)400...1820°C	≤ 3 K	0,132 K
T	-200...400°C	≤ 2 K	0,056 K
W(C) ⁽²⁾	0...2300°C	≤ 2 K	0,18 K
E	-200...900°C	≤ 2 K	0,038 K

(1) Error & resolution values for 400...1820°C.

(2) W5Re/W26Re

With linearization

(temperature-linear in °C or °F)

Input resistance: ≥ 1MΩ

Cold-junction compensation (CJC):

built in

Input circuit monitor

Current through sensor: ≤ 1 μA

Reverse-polarity monitor is triggered at 10 °C below span start.

The sensor's status can be processed in the engineering as a logical signal.

Additional error of internal CJC

0,5 K per 10 K terminal temperature

External temperature selectable:

0...60 °C or 32...140 °F

Fig. 7 Hardware and software structure

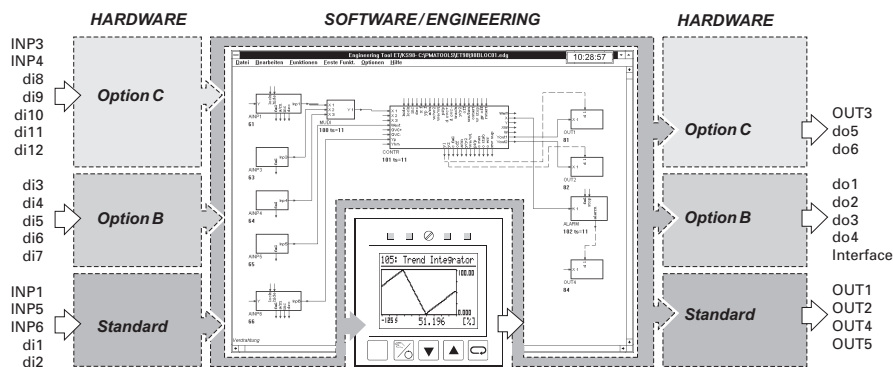

Fig. 8 Electrical connections

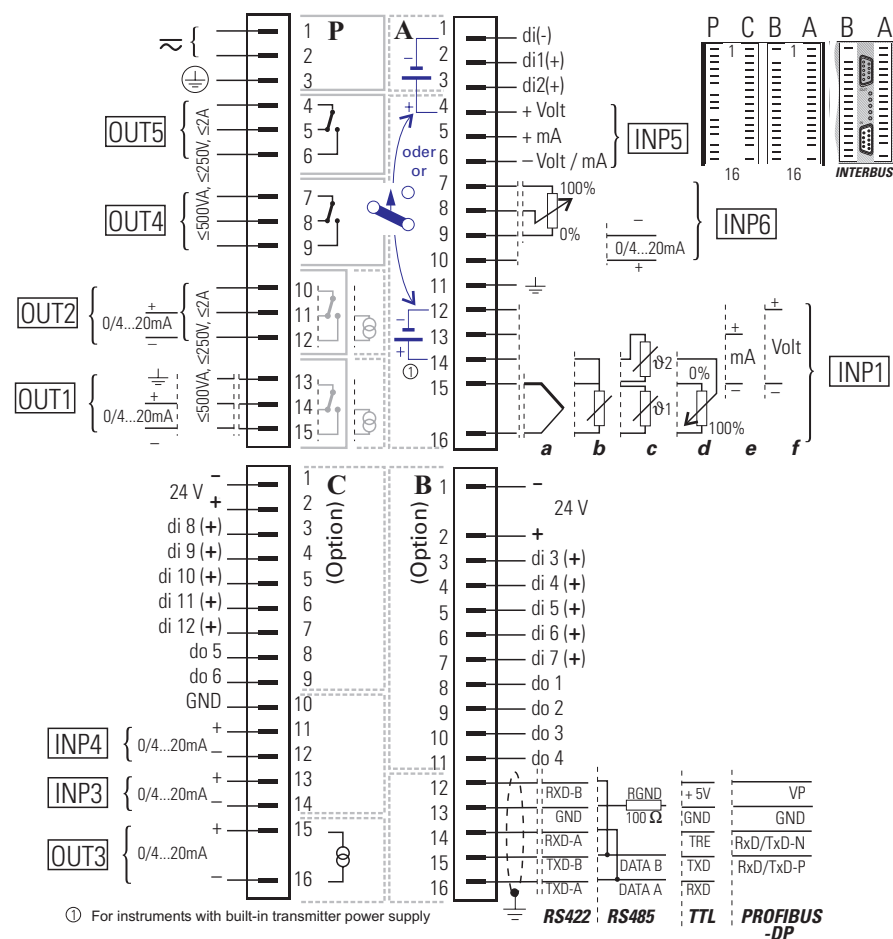
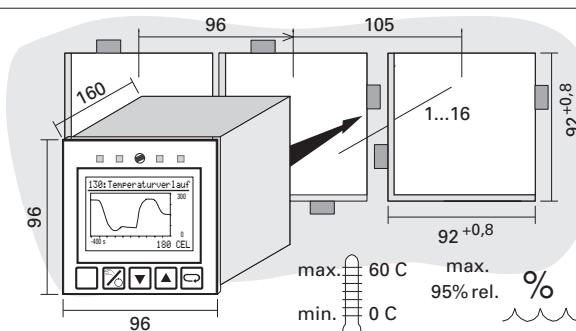

Fig. 9 Overall dimensions (in mm)



Resistance thermometer

Pt 100 to DIN IEC 751, and temperature difference 2 x Pt 100

Range	Error	Resolution
-200,0...250,0 °C	≤0,5 K	0,024 K
-200,0...850,0 °C	≤1,0 K	0,05 K
2 x -200,0...250,0 °C	≤0,5 K	0,024 K
2 x -200,0...250,0 °C	≤0,1 K	0,05 K

Linearization in °C or ° F

Two or three-wire connection.

Two-wire connection with lead resistance adjustment.

Lead resistance: ≤ 30 Ω per lead

Sensor current: ≤ 1 mA

Input circuit monitoring for sensor/lead break, and lead short circuit.

Potentiometric transducer

R _{total} inkl. 2 x R _L	Error	Resolution
0...500 Ω	≤0,1 %	≤0,02 Ω

Resistance-linear

Sensor current: ≤ 1 mA

Matching/scaling with sensor connected.

Input circuit monitoring for sensor/lead break, and lead short circuit.

Resistance input

Range	Error	Resolution
0...250 Ω	≤0,25 Ω	<0,01 Ω
0...500 Ω	≤0,5 Ω	<0,02 Ω

Direct current 0/4...20mA

Range	Error	Resolution
0/4...20 mA	≤0,1 %	≤0,8 μA

Input resistance: 50 Ω

Input circuit monitor with 4...20mA: triggered when I ≤ 2 mA

Direct voltage

Range	Error	Resolution
0/2...10 V	≤0,1 %	≤0,4 mV

Eingangswiderstand ≥ 100 kΩ

Signal input INP5

Differential amplifier input

Up to 6 controllers can be cascaded, if there is no other galvanic connection between them. If there is, only 2 inputs can be cascaded.

Direct current and voltage

Technical data as for INP1, except for:
Limiting frequency: = 0,25 Hz
Measurement cycle: 800 ms
Input resistance (voltage): ≥ 500 kΩ

Signal input INP6

Limiting frequency: = 0,5 Hz

Measurement cycle: 400 ms

Potentiometric transducer

Technical data as for INP1, except for:

R _{total} inkl. 2 x R _L	Error	Resolution
0...1000 Ω	≤0,1 %	≤0,04 Ω

Direct current 0/4...20 mA

Technical data as for INP1

Optional signal inputs INP3, INP4

Galvanically-isolated differential amplifier inputs.

Measurement cycle: 100 ms

Direct current

Technical data as for INP1 except R_i = 43Ω

INP3 as mV signal

(KS98: 9407 9xx x2xx1)
Direct current: -50...1300 mV linear
Resolution: 0,34 mV
Input resistance: > 1 MΩ

Control inputs di1...di12

di1, di2: standard
di3...d7: Option B
di8...di12: Option C

Opto-coupler

Nominal voltage: 24 VDC, external
Current sink (IEC 1131 Type 1)
Logic „0“ (Low): -3...5 V
Logic „1“ (High): 15...30 V
Current demand: approx. 6 mA
(see Fig. 8 for galvanic connections and isolation).

Built-in transmitter supply (optional)

Can be used to energize a two-wire transmitter or up to 4 opto-coupler inputs.
Galvanically isolated.
Output: ≥ 17,5 VDC, max. 22 mA

Factory setting

The transmitter supply is available at terminals A12 and A14, if INP1 is configured for current input and thermocouples. By means of internal switches, the voltage can be applied to terminals A1 and A4, where it is always available, irrespective of the configuration.

OUTPUTS

Outputs OUT1, OUT2, OUT4, OUT5

Relay or current/logic signal, depending on version.

Relay outputs

Relays have potential-free change-over contacts.

Max. contact rating:

500 VA, 250 V, 2 A with 48...62 Hz, cos 0,9

Minimum rating: 12 V, 10 mA AC/DC
Useful life: 10⁶ switching cycles under max. load

Note:

If the relays operate external contactors, these must be fitted with RC snubber circuits to prevent excessive switch-off voltage peaks!

OUT1, OUT2 as current outputs

Galvanically isolated from the inputs
0/4...20 mA, selectable
Signal range: 0...22 mA
Resolution: ≤ 6 μA (12 bits)
Error: ≤ 0,5%
Load: ≤ 600 Ω
Load effect: ≤ 0,1%
Limiting frequency: approx. 1 Hz

OUT1, OUT2 as logic signal

0 / ≥ 20 mA with a load ≥ 600 Ω
0 / > 12 V with a load > 600 Ω

Output OUT3 (Option C)

Galvanically isolated
Technical data as for OUT1, OUT2

Control outputs do1..do6

do1...do4: with Option B
do5, do6: with Option C

Opto-coupler outputs
(see Fig. 8 for galvanic isolation).

Grounded load: common positive control voltage

Switch rating: 18...32 VDC; I_{max} ≤ 70 mA

Internal voltage drop: ≤ 0,7V with I_{max}

Protective circuit: thermal, switches off with overload.

POWER SUPPLY

Depends on version, see Ordering Data.

Alternating current

90...250 VAC

Frequency: 48...62 Hz

Power consumption: approx. 14,2 VA;
8,5 W (max. configuration).

Universal current 24 V UC

24 VAC, 48...62 Hz/24 VDC

Tolerance: +10...-15% AC

18...31,2 VDC

Power consumption

AC: approx. 14,2 VA; 8,5 W

DC: 14,2 W (max. configuration).

Behaviour after power failure

Structure, configuration, parameters, set-points

Permanent data storage in an EEPROM

Data for timer, programmer, integrator, counter, etc.

Temporary storage in a capacitor-buffered RAM ($\geq 0,5$ hours).

Real-time clock (optional)

Buffer capacitor provides back-up for at least 2 days.

FRONT INTERFACE PORT (STANDARD)

Front-panel socket for PC adapter (see „Accessories“). By means of the Engineering Tool ET/KS 98, the controller can be remotely structured, configured, and its parameters set.

BUS INTERFACE

Galvanically isolated, choice of TTL or RS 422/485 operation.

Note: In order to convert TTL signals to RS 422/485, an interface module is required (see „Accessories“).

Protocol: ISO 1745

Transmission speed: 2400 / 4800 / 9600 / 19.200 bits/s

Address range: 00...99

Number of controllers per bus:

With RS 422/485: 32

With TTL signals: max. 32 interface modules on one bus. Above this value, the only limit is the address range (00...99)

PROFIBUS-DP INTERFACE

According to EN 50 170, Vol. 2.

Reading and writing of all process data, parameters, and configuration data.

Configurable process data modules

The Engineering Tool ET/KS 98 is used to select the functions DPREAD and DPWRITE max. 4 times each.

By suitable internal connections with the inputs/outputs of these two, functions, any internal signal can be applied to the PROFIBUS-DP interface.

The parameter channel provides non-cyclical access to all operational parameters and configuration data.

Module	DPREAD	DPWRITE	Parameter-channel
a	1	1	-
b	1	1	x
c	2	2	x
d	3	3	x
e	4	4	x

Data format (configurable)

Real values are transmitted in the IEEE format (REAL) or in the 16-bit fixed point format (FIX) with one decimal digit (configurable).

Memory requirements

Module	Read		Write	
	FIX	REAL	FIX	REAL
a	18	26	18	26
b	26	34	26	34
c	44	60	44	60
d	62	86	62	86
e	80	112	80	112

Diagnostics/behaviour on error

The functions DPREAD and DPWRITE have digital status outputs for signalling various error conditions.

Transmission speeds and cable lengths (automatic transm. speed detection)

Speed	Max. cable length
9,6 kbit/s	1200 m
187,5 kbit/s	1000 m
500 kbit/s	400 m
1,5 Mbit/s	200 m
12,0 Mbit/s	100 m

Addresses

0...126 (factory setting: 126)

Remote addressing is possible.

Other functions

Sync and Freeze

Connection

AMP flat-pin connector, (via adapter to screw terminals or Sub-D connector, see Accessories).

Terminating resistors

Internally selectable with wire-hook switches.

Cable

According to EN 50 170, Vol. 2.

Required accessories

Engineering Set PROFIBUS-DP, consisting of:

- GSD file, Type file
- PROFIBUS manual
- Function block(s) for Simatic S5/S7

DISPLAYS

LCD point-matrix display with back lighting.

Display area: 64 x 128 points

Status display:

4 yellow LEDs for logic status

ENVIRONMENTAL CONDITIONS

Permissible temperatures

For operation: 0...60 °C

For specified accuracy: 0...55 °C

Combination of INTERBUS and standard or modular Option C: Max. operating temperature 0...45°C !

Storage and transport: -20...60 °C

Temperature effect: $\leq 0,15\%$ / 10 K

Climatic category

KUF to DIN 40 040

Relative humidity: $\leq 75\%$ yearly average, no condensation

Shock and vibration

Vibration test Fc

To DIN 68-2-6 (10...150 Hz)

Unit in operation: 1g or 0,075 mm,

Unit not in operation: 2g or 0,15 mm

Shock test Ea

To DIN IEC 68-2-27 (15g, 11 ms)

ELECTROMAGNETIC COMPATIBILITY

Complies with EN 50 081-1 and EN 50 082-2 for unrestricted use in rural and industrial areas.

Electrostatic discharge

Test to IEC 801-2,

8 kV air discharge

4 kV contact discharge

High-frequency interference

Test to ENV 50 140 (IEC 801-3)

80...1000 MHz, 10 V/m

Effect: $\leq 1\%$

HF interference on leads

Test to ENV 50141 (IEC 801-6)

0,15...80 MHz, 10 V

Effect: $\leq 1\%$

Low-frequency magnetic field

Test to IEC 1000-4-8

No effect with 50 Hz, 30 A/m

Fast pulse trains (burst)

Test to IEC 801-4 2 kV applied to leads for supply voltage, and signal leads

High-energy single pulses (surge)

Test to IEC 801-5

1 kV symmetric or 2 kV asymmetric on leads for supply voltage.

0,5 kV symmetric or 1 kV asymmetric on signal leads.

GENERAL

Housing

Plug-in module, inserted from front.
Material: Makrolon 9415,
flame-retardant, self-extinguishing
Flammability class: UL 94 VO

Protection mode

(to EN 60 529, DIN VDE 0470)
Front: IP 65
Housing: IP 20
Terminals: IP 00

Safety tests

To EN 61 010-1 (VDE 0411-1)
Overvoltage category: III
Contamination class: 2
Working voltage range: 300 VAC
Protection class: I

CE marking

The controller meets the European Directives regarding „Electromagnetic Compatibility“ and „Low-voltage equipment“ (see also „Safety tests“)

Electrical connections

Flat-pin connectors to DIN 46 244 for
1 x 6,3 mm or 2x 2,8mm

Mounting method

Panel mounting with 4 fixing clamps at top/bottom

Mounting position

Not critical

Weight

Approx. 0,75 kg with all options

Accessories

3-language operating and safety instructions (GB/D/F)
4 fixing clamps

ACCESSORY EQUIPMENT

Interface module and interface cable

Up to 16 controllers with TTL interface can be connected to the interface module.
Connection is by means of the separately-ordered interface cable (1m long).

Via the RS 422/485 interface (D-type connectors), the data are transmitted up to a distance of 1 km.

Supply voltage

230 VAC / 115 VAC / 24 VAC,
depending on version

Electrical connections

Supply voltage: via screw terminals
Interfaces: Sub-D connectors

Mounting

To standard rail, e.g. to EN50035

Dimensions

158 x78x 60 mm (LxWxH)

Engineering Tool ET/KS 98plus

For scope of functions, see page 3.

Hardware & software platform

Windows 3.1/3.11 or Windows 95 must be installed and operable. Graphic resolution: at least 800 x 600 pixels. Operation with mouse (preferred).

Simulation SIM/KS 98

Software package for simulating the KS 98 on a standard PC under Windows. All functions of the KS 98 are possible, plus:

- Simulation of inputs/outputs
- Trend display
- „Turbo“ mode

PC-Adapter

Adapter cable for connecting a PC (Engineering Tool) to the front-panel interface socket of the KS 98.

ORDERING INFORMATION

Every controller can be operated, configured, and the parameters set via the front-panel keys.

By means of the Engineering Tool ET/KS 98, every KS 98 can be matched precisely to the individual requirements.

Ex-factory settings for controllers with standard configuration

Basic version 9407 963 00001 (switching output)

- Signaller, 2-point, 3-point, 3-point stepping
- Process value conditioning (filter and characterizer)
- 2 alarms (selectable: x, xw, weff, y)
- Trend display for x, xw, weff
- Bargraph display for x and weff
- Program controller with 4 profiles of 20 segments each

Basic version 9407 965 00001 (continuous output)

as above for switching outputs, except:

- Continuous controller including „split range“ operation, switching outputs (logic)
- Analog output for x, xw, weff or y2

Controllers with Option B Functions

as above for corresponding basic version, plus:

- Disabling of front-panel keys via a control input
- 4 control outputs from programmer
- 7-day clock for start/stop of programmer (Option B with clock)

Controllers with Option C

Functions as above for corresponding basic version, plus:

- Three-element control
- Override control +, or „hard manual“
- Galvanically isolated ratio control (x1÷x2)
- Output for the programmer set-point
- Two additional control outputs from programmer

Settings for application-specific controllers

Cascade controller

MASTER CONTROLLER

- Process value input INP5
- Process value conditioning (filter and characterizer)
- Trend displays for control deviation and process value

SLAVE CONTROLLER

- Same as master controller, but with process value input INP1
- Selectable controller type depending on switching/continuous basic version
- Position feedback via input INP6

FLOW CONTROLLER

- Temperature and pressure-corrected flow measurement for mass-flow control (with or without square root extraction)
- Trend displays for flow and control deviation
- Flow totalizing with creep flow cut-off
- Display of flow up to 99.999.999
- Re-set of flow counter from the front after entering an access code
- Output of counter pulses (all and every 1000)
- Selectable controller type depending on switching/continuous basic version

PROGRAM CONTROLLER WITH 10 PROFILES

- 10 profiles, each with 20 segments
- 2 analog control outputs
- 6 digital control outputs
- One controller per analog output
- Operation from the front of the analog programmer
- Operation can be disabled via control input
- Selectable controller type depending on switching/continuous basic version
- 6 digital control outputs do1...do6 (opto-coupler isolated, only with Option B)

Calorimetric counter

- Totalizing of flow and heating/cooling energy
- Creep flow cut-off
- Output of counting pulses for flow and heating/cooling energy (OUT4,5)
- Output of flow and calorimetric values as 0...20mA signals
- Galvanically isolated flow output

- signal (Option C)
- Alarm monitoring for temperature and flow (Option C)

Flow calculator

(Possible without Option B and C)

- Temperature and pressure-corrected flow measurement for mass-flow control (with or without square root extraction)

- Measuring cycle 400 ms
- Trend displays for flow and control deviation
- Creep flow cut-off
- Output of counter pulses (OUT4)
- Alarm monitoring for temperature, pressure and flow (OUT5)

AUSFÜHRUNGEN

	9	4	0	7	9					1
Basic version	KS 98 standard				6					
	KS 98 with transmitter power supply				7					
Supply and control outputs	90...250 V AC 4 relays				3					
	90...250 V AC 2 relays+ 2 current outputs				5					
	24 V UC, 4 relays				7					
	24 V UC, 2 relays+ 2 current outputs				9					
Option B	Without Option B				0					
	TTL interface + di/do				1					
	RS422 + di/do + watch				2					
	PROFIBUS-DP + di/do				3					
Option C	Interbus + di/do				4					
	Without Option C				0					
	INP3, INP4, OUT3, di/do				1					
Dedicated control functions	INP3 (mV), INP4, OUT3, di/do				2					
	Single-loop controller (basic version)				0					
	Cascade controller				1					
	Flow controller ¹⁾				2					
	Program controller				3					
Engineering Tool!	Calorimetric counter/controller ²⁾				4					
	Flow calculator ²⁾				5					
Configuration	Standard configuration				0					
	Customer-specific configuration ³⁾				9					

¹⁾ Option C is necessary

²⁾ Basic version with 2 current outputs is necessary

³⁾ The required configuration is defined by means of a CONF-098-XXXXX number which is generated with the necessary engineering service.

⁴⁾ to connect Engineering Tool ET/KS 98 plus via the front interface

⁵⁾ Upgrade from ET/KS 98 ≤ V 2.x to ET/KS 98plus V 3.x

⁶⁾ Incl. RS232 cable, 10 m cable for RS422

⁷⁾ 3-languages

Accessories

PC-Adapter ⁴⁾	9407 998 00001
Engineering Tool ET/KS 98plus	9407 999 06401
Engineering Tool ET/KS 98plus (10)	9407 999 06411
ET/KS 98plus Update	9407 999 06421
ET/KS 98plus Upgrade ⁵⁾	9407 999 06431

Accessories (continued)

Simulation SIM/KS 98	9407 999 08801
Simulation SIM/KS 98 (10)	9407 999 08811
SIM/KS 98 Update	9407 999 08821
MSIServer – 32Bit DDE-Server	9407 999 07101
Converter RS232/RS422 ⁶⁾	9407 998 00041
Interface cable 1 m	9404 407 50011
Interface module 230 VAC	9404 429 98001
Interface module 115 VAC	9404 429 98011
Interface module 24 VAC	9404 429 98021
ES KS 98/PROFIBUS (D)	9407 999 10011
ES KS 98/PROFIBUS (E)	9407 999 10001
ES KS 98/Interbus (D)	9407 999 10211
ES KS 98/Interbus (E)	9407 999 10201
Screw-terminal adapter	9407 998 00021
D-type connector adapter	9407 998 00031

Documentation

Operating instructions KS 98 / KS 98+ (D)	9499 040 44318
Operating instructions KS 98 / KS 98+ (E)	9499 040 44311
Operating instructions KS 98 / KS 98+ (F)	9499 040 44332
Instructions for single loop controller ⁷⁾	9499 040 51001
Instructions for cascade controller ⁷⁾	9499 040 51101
Instructions for flow controller ⁷⁾	9499 040 51201
Instructions for program controller ⁷⁾	9499 040 51301
Instructions for calorimetric controller ⁷⁾	9499 040 51401
Instructions for flow calculator ⁷⁾	9499 040 51501
Operating instructions ET/KS 98plus ⁷⁾	9499 040 45701
Interface description	
PROFIBUS-Protocoll (D)	9499 040 52718
PROFIBUS-Protocoll (E)	9499 040 52711
Interface description ISO 1745-Protocoll (D)	9499 040 45118
Interface description ISO 1745-Protocoll (E)	9499 040 45111
Manual KS 98 / KS 98+ (D)	9499 040 44918
Manual KS 98 / KS 98+ (E)	9499 040 44911
Manual KS 98 / KS 98+ (F)	9499 040 44912

Engineering services

Configuration and parameters to specification	DIKS ENG 98001
„Mini“ change (max. 5 additional functions)	DIKS ENG 98002
Complete Engineering (detailed specification required!)	DIKS ENG 98003



PMA
 Prozess- und Maschinen- Automation GmbH
 P.O Box 31 02 29
 D - 34058 Kassel
 Tel.: +49 - 561 - 505 1307
 Fax: +49 - 561 - 505 1710
 E-mail: mailbox@pma-online.de
 Internet: http://www.pma-online.de

Your local representative: