



by **KELLER**  
infrared  
temperature  
solutions **ITS**



## APPLICATION Aluminium

Optical temperature measurement  
during extrusion, forging and rolling  
of aluminium



5 <sup>★ ★ ★ ★ ★</sup>  
years  
warranty

**QUALITY**  
made in Germany



### Optical temperature measurement of aluminium

The acquisition of thermal radiation for measuring the temperature of aluminium is one of the most difficult measuring tasks in radiation thermometry. On the one hand, aluminium is a very poor source of radiant heat, so that infrared radiation is extremely low, especially at low temperatures. On the other hand, the surface properties and thus the emissivity of aluminium can vary considerably. Ordinary pyrometers react extremely to such influences, so that no reliable temperature measurement is possible.

### Patented measuring method

Based on a patented measurement value processing and constant light technology, KELLER ITS has developed a short-wave measuring pyrometer which can reliably detect and evaluate even the smallest photo currents in the picoamp range. This has been made possible by a combination of light-intensive optics, a highly sensitive photodiode, an extremely low-noise signal processing as well as an adaptive software algorithm to compensate for the influence of ambient temperature.

Even in the worst case scenario, i.e. with bare metals with an emissivity of only 10 % and with at the same time the fastest measuring time of a few milliseconds, the pyrometers deliver stable measured values even from 75 °C. Thanks to the short response time, it is ideally suitable even on moving objects as after the extruder or for monitoring the temperature of aluminium billets before hot forming.

### Aluminium forging

Before forging, rolling or extrusion, the billets, ingots or slabs are heated up to the required temperature. Since the forging temperature is close to the melting temperature of aluminium, this is a decisive, quality-relevant factor. In order to simultaneously achieve a high material throughput and short cycle times for automatic hot pressing, fast and precise monitoring and maintenance of a constant process temperature is required.

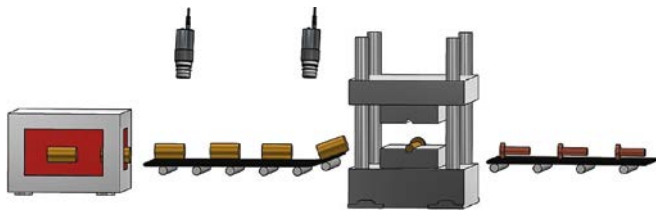

### Aluminium extrusion press

The overall temperature balance of an extrusion press is decisive for the press speed and the quality of the extrusion strand. The billet, the billet holder and the tools are preheated. In addition, the forming of billets generates forming and frictional heat. The temperature of the extruded profile strand increases. Too high temperatures can lead to hot or transverse cracks and thus to damage to the profile strand. There is also the risk of increased wear of the tool. A non-destructive, fast and safe temperature measurement at the exit of the extrusion press is decisive for a constant product quality.

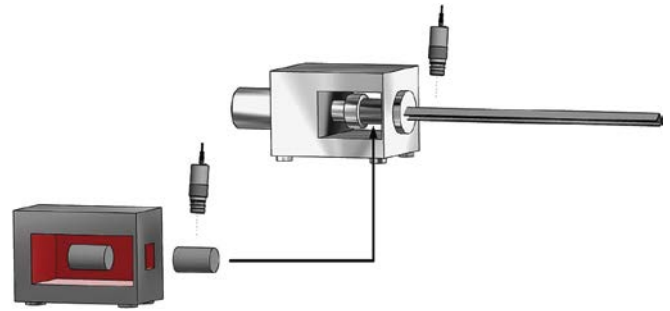

### Measuring solution

The CellaTemp PA 28/29, PX 28/29, PK 25 and PKL 29 pyrometers have been especially developed for measuring aluminium and bare metals. Due to the selective measuring wavelength, the pyrometers do not react to interfering reflections from daylight. The influence of the surface is also minimized at this wavelength. It is therefore possible to measure the temperature of bare metals with low emissivity and low temperatures from a safe distance.

Depending on the temperature range, the size of the object and the measuring distance, there are different types of devices available.

To check the alignment to the measuring point, CellaTemp PA / PX 28 / 29 can be equipped with a through-the-lens sighting, a laser pilot light or a video camera. The measuring distance can be adjusted very precisely in the range of 300 mm to infinitely by a focus lens very accurate and continuously progressive thanks to its unique worm thread. On the bright display the production temperature can be read at any time, even from a distance of several meters.

The CellaTemp PKL 29 is equipped with a green LED pilot light. It indicates the exact size of the measuring field.

### IO-Link Interface Technology

In addition to the classic 0(4)-20 mA current output and a switching output, the pyrometers of the CellaTemp PK and CellaTemp PX series are equipped with the innovative IO-Link interface. Due to its simple electrical and software integration into automation systems, IO-Link is referred to as the industry's USB interface for plant and machine control. All established manufacturers of programmable logic controllers (PLC) have been involved in the specification and development of this worldwide standardized interface technology according to IEC 61131-9. This means that devices with IO-Link can be used in all leading fieldbus systems, such as Profibus, Profinet, EtherCAT, CAN-Bus or Modbus for process automation, independent of system and manufacturer, and enable consistent communication from the lowest field level over the control level to the ERP system.

Using the digital communication interface, further signals, diagnostic data and status messages are transmitted to the control system in parallel to the measuring and switching signal. Depending on the material and the operating conditions, the configuration parameters of the pyrometers can also be dynamically adjusted during operation.

## Measuring systems

Pyrometer	Design	Measuring range	Sighting device	Interface	Mounting accessories
PK 25 AF 1	stationary	75 – 650 °C	–	IO-Link	PS 01/I AF 2 PS 11/U AF 1
PKL 29 AF 1	stationary	180 – 1200 °C	LED pilot light	IO-Link	PS 01/I AF 2 PS 11/U AF 1
PX 28 AF 10(/L)	stationary	75 – 650 °C	Through-the-lens-sighting or laser pilot light (/L)	IO-Link	PA 20-071 PA 83-010
PA 28 AF 10(/L)				RS 485	
PX 29 AF 10(/L)	stationary	150 – 800 °C	Through-the-lens-sighting or laser pilot light (/L)	IO-Link	PA 20-071 PA 83-010
PA 29 AF 10(/L)				RS 485	
PX 29 AF 21(/L)	stationary	180 – 1200 °C	Through-the-lens-sighting or laser pilot light (/L)	IO-Link	PA 20-071 PA 83-010
PA 29 AF 21(/L)				RS 485	
PT 128 AF 10	portable	75 – 650 °C	Through-the-lens-sighting	USB	–
PT 129 AF 10	portable	150 – 800 °C	Through-the-lens-sighting	USB	–
PT 129 AF 21	portable	180 – 1200 °C	Through-the-lens-sighting	USB	–

## Mountings

### Mounting PA 83-010

#### consisting of:

- Cooling jacket PA 20/M AF 1
- Air purge PZ 20/A AF 1
- Intermediate tube PZ 20/C
- Clamping collar PZ 20/L AF 2
- Dust stop PZ 10/T
- Flange PB 08/R AF 1
- Mounting PB 08/Q AF 1

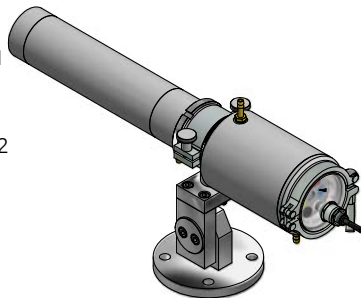

### Mounting PA 20-071

#### consisting of:

- Mounting bracket PA 11/U
- Mounting angle, adjustable PA 11/K



## Accessories

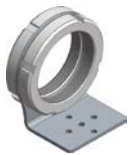

Mounting bracket  
with 2 shaft nuts  
PA 11/U



Quartz window  
PS 01/I AF 2



Mounting angle  
PS 11/U AF 1



Portable pyrometer CellaPort PT series

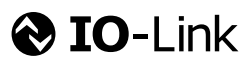

Pyrometer LLC | 70 Weber Ave. | Ewing, NJ 08638  
www.pyrometer.com | T: 609.443.5522