

Questionnaire for temperature measurement in PLD processes

For a customized quotation please fill out this form.
Your information will help us recommend the best solution for your application.

Client Address

Company	Department	Web
P.O. Box	Street	
City Code	City	Country
Contact Person	Tel.	E-mail

Industry

Application

Description of the measurement (Please attach pictures or drawings if possible).

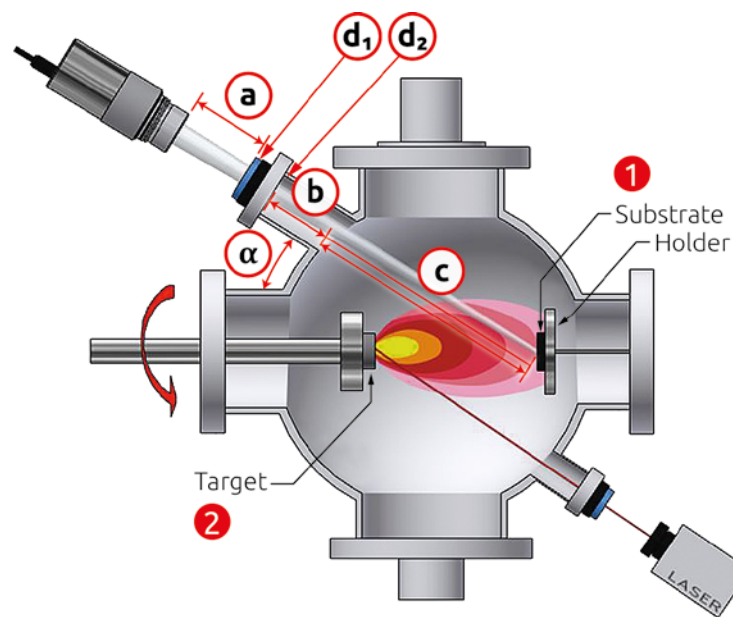

Dimensions of the measuring task

Do you want to measure the temperature of
 the substrate **1** the target **2**

Distance between pyrometer and window **a** = _____ mm

Distance between tube opening and opening of the vacuum chamber **b** = _____ mm

Distance between opening of the vacuum chamber and substrate **c** = _____ mm

Diameter of the sighting window **d₁** = _____ mm

Diameter of the sighting tube **d₂** = _____ mm

Sighting angle **α** = _____ °

1 Substrate

Material _____

Temperature from _____ to _____ °C

Thickness from _____ to _____ mm

2 Target (Deposition material)

Material _____

Process of vaporisation electron beam laser other _____

Temperature from _____ to _____ °C

Target size of the object _____ mm

Holder

Material _____

Is it cool down?

Yes

No

Temperature _____ °C

Heating source

Laser -> wavelength _____

Plasma -> nature of the gases _____

Induction

Microwaves

Flame

other _____

Task information

How long does the coating process take?

_____ hours days

Speed of growth _____

Is the measured object moving?

Yes

No

Is the measured object permanently visible?

Yes

No

How is the temperature measured so far?

not at all

Thermocouple

Pyrometer

other _____

Ambient temperature of the pyrometer _____ °C

Material of the sighting window?

Quartz

Sapphire

Borosilicate

other _____

Specification of the instrument

Type of pyrometer

portable

stationary

Sighting device

Through-the-lens

Video camera

Laser spot light

Signal processing

Output signal/Digital interface

0/4-20 mA

RS 485

USB

IO-Link

other _____

Should the measured values be recorded?

Yes

No

Is a central data recording existing?

Yes

No

Additional details or description



KELLER HCW GmbH · Infrared Temperature Solutions (ITS)
Carl-Keller-Str. 2-10 · 49479 Ibbenbüren · Germany
Tel. +49 (0) 5451 850 · Fax +49 (0) 5451 85412 · www.keller.de/its · its@keller.de

KELLER A DIVISION OF **GRUPE LEGRIS INDUSTRIES**

